

**01 - 05.1**

01.06.GB

**LDM valves  
with Johnson Controls actuators**



## Kv coefficient calculation

Calculation itself is carried out with respect to conditions of regulating circuit and operating medium according to equations mentioned below. Control valve must be designed to be able to regulate maximal flow quantity at given operating conditions. At the same time it is necessary to check whether minimal flow quantity can be even regulated or not.

Condition is the following ratio  $r > Kvs / Kv_{min}$

Because of eventual minus tolerance 10% of  $Kv_{100}$  against  $Kvs$  and requirement for possible regulation within range of maximal flow (decrement and increase of flow), producer recommends to select  $Kvs$  value higher than maximal operating  $Kv$  value:

$$Kvs = 1.1 \div 1.3 Kv$$

It is necessary to take into account to which extent  $Q_{max}$  involve "precautionary additions" that could result in valve oversizing.

## Relations of Kv calculation

		Pressure drop $p_2 > p_1/2$ $\Delta p < p_1/2$	Pressure drop $\Delta p \geq p_1/2$ $p_2 \leq p_1/2$
Kv =	Liquid	$\frac{Q}{100} \sqrt{\frac{\rho_1}{\Delta p}}$	$\frac{Q}{100} \sqrt{\frac{\rho_1}{\Delta p}}$
	Gas	$\frac{Q_n}{5141} \sqrt{\frac{\rho_n \cdot T_1}{\Delta p \cdot p_2}}$	$\frac{2 \cdot Q_n}{5141 \cdot p_1} \sqrt{\rho_n \cdot T_1}$
	Superh. steam	$\frac{Q_m}{100} \sqrt{\frac{v_2}{\Delta p}}$	$\frac{Q_m}{100} \sqrt{\frac{2v}{p_1}}$
	Sat. steam	$\frac{Q_m}{100} \sqrt{\frac{v_2 \cdot x}{\Delta p}}$	$\frac{Q_m}{100} \sqrt{\frac{2v \cdot x}{p_1}}$

## Above critical flow of vapours and gases

When pressure ratio is above critical ( $p_2 / p_1 < 0.54$ ), speed of flow reaches acoustic velocity at the narrowest section. This event can cause higher level of noisiness. Then it is convenient to use a throttling system ensuring low noisiness (multi-step pressure reduction, damping orifice plate at outlet).

## Dimensions and units

Marking	Unit	Name of dimension
Kv	$m^3 \cdot h^{-1}$	Flow coefficient under condition of units of flow
$Kv_{100}$	$m^3 \cdot h^{-1}$	Flow coefficient at nominal stroke
$Kv_{min}$	$m^3 \cdot h^{-1}$	Flow coefficient at minimal flow rate
Kvs	$m^3 \cdot h^{-1}$	Valve nominal flow coefficient
Q	$m^3 \cdot h^{-1}$	Flow rate in operating conditions ( $T_1, p_1$ )
$Q_n$	$Nm^3 \cdot h^{-1}$	Flow rate in normal conditions ( $0^\circ C, 0.101 Mpa$ )
$Q_m$	$kg \cdot h^{-1}$	Flow rate in operating conditions ( $T_1, p_1$ )
$p_1$	MPa	Upstream absolute pressure
$p_2$	MPa	Downstream absolute pressure
$p_s$	MPa	Absolute pressure of saturated steam at given temperature ( $T_1$ )
$\Delta p$	MPa	Valve differential pressure ( $\Delta p = p_1 - p_2$ )
$\rho_1$	$kg \cdot m^{-3}$	Process medium density in operating conditions ( $T_1, p_1$ )
$\rho_n$	$kg \cdot Nm^{-3}$	Gas density in normal conditions ( $0^\circ C, 0.101 Mpa$ )
$v_2$	$m^3 \cdot kg^{-1}$	Specific volume of steam when temperature $T_1$ and pressure $p_2$
$v$	$m^3 \cdot kg^{-1}$	Specific volume of steam when temperature $T_1$ and pressure $p_1/2$
$T_1$	K	Absolute temperature at valve inlet ( $T_1 = 273 + t_1$ )
x	1	Proportionate weight volume of saturated steam in wet steam
r	1	Rangeability

## Flow characteristic selection in regard of valve stroke

To make right selection of valve flow characteristic, it is suitable to carry out checking of what stroke values will be reached in different operation states. We recommend to carry out such checking at least for minimal, nominal and maximal flow rates. The principle for flow characteristic selection is to avoid, if possible, 5-10% of the beginning and end of the valve stroke range.

To calculate valve stroke at different operating conditions with different types of flow characteristics is possible with the advantage of using LDM's calculation programme VALVES. The programme serves for complete design of valve from  $Kv$  calculation to specification of a concrete valve with its actuator.

## Valve flow characteristics

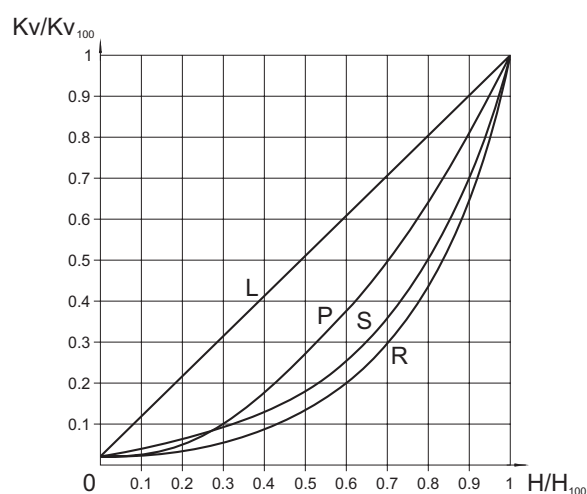

- L - linear characteristic  
 $Kv/Kv_{100} = 0.0183 + 0.9817 \cdot (H/H_{100})$
- R - equal-percentage characteristic (4-percentage)  
 $Kv/Kv_{100} = 0.0183 \cdot e^{(4 \cdot H/H_{100})}$
- P - parabolic characteristic  
 $Kv/Kv_{100} = 0.0183 + 0.9817 \cdot (H/H_{100})^2$
- S - LDM spline® characteristic  
 $Kv/Kv_{100} = 0.0183 + 0.269 \cdot (H/H_{100}) - 0.380 \cdot (H/H_{100})^2 + 1.096 \cdot (H/H_{100})^3 - 0.194 \cdot (H/H_{100})^4 - 0.265 \cdot (H/H_{100})^5 + 0.443 \cdot (H/H_{100})^6$

## Principles for plug type selection

V-ported plugs should not be used in above - critical differential pressures with inlet pressure  $p_1 \geq 0,4$  MPa and for regulation of saturated steam. In these cases we recommend to use a perforated plug. The perforated plug should be also used always when cavitation may occur due to a high differential pressure value or valve ports erosion caused by high speed of process medium flow. If the parabolic plug is used (because of small Kvs) for pressures  $p_1 \geq 1,6$  MPa and above - critical differential pressures, it is necessary to close both plug and seat with a hard metal overlay, i.e. stellite trim.

## Packing - O-ring EPDM

Packing is designed for non-aggressive media with temperature from 0° to 140°C. Packing excels with its reliability and long time tightness. It has ability of sealing even if the valve stem is a bit damaged. Low frictional forces enables valve to be actuated with a low-linear-force actuator. Service life of sealing rings depends on operating conditions and it is more than 400 000 cycles on average.

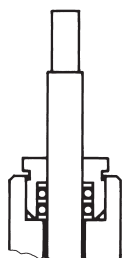

Applied to RV 102, RV 103

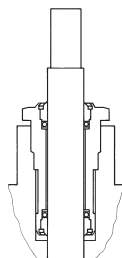

Applied to RV 2xx

## Packing - DRSpack® (PTFE)

DRSpack (Direct Radial Sealing Pack) is a packing with high tightness at both low and high operating pressure values.

It is the most used type of packing suitable for temperatures ranging from 0° to 260°C. The pH range is from 0 to 14. The packing enables using of actuators with low linear force. The design enables an easy change of the whole packing. The average service life of DRSpack® is more than 500 000 cycles.

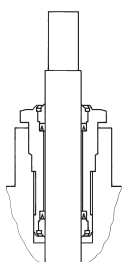

## Packing - Graphite

This type of packing can be used for media with temperature up to 550°C and pH range: 0 to 14. Packing can be "sealed up" either by screwing the packing screw in or adding another sealing ring. In regard of intensive frictional forces, graphite packing is suitable for actuators with a sufficient linear force.

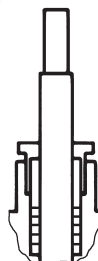

## Packing - Bellows

Bellows packing is suitable for low and high temperatures ranging from -50° to 550°C. Bellows ensures absolute tightness to environment. Packing is equipped with safety PTFE packing as standard to prevent medium from leaking in case of damage to bellows. Intensive linear forces are not required.

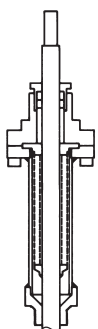

## Application of bellows packing

Bellows packing is suitable for applications with very aggressive, toxic or other dangerous media that require absolute tightness to environment. In such case, it is necessary to check compatibility of used body material as well as the valve inner parts material with process medium. It is recommended to use bellows with safety packing preventing medium from leaking in case of damage to bellows when there is an extremely dangerous process medium used.

Bellows is also a great solution to use of process medium either with temperature below zero when ice accretions cause premature damage to packing or with high temperatures when bellows ensures medium cooling.

## Rangeability

Rangeability is the ratio of the biggest value of flow coefficient to the smallest value. In fact it is the ratio (under the same conditions) of highest regulated flow rate value to its lowest value. The lowest or minimal regulated flow rate is always higher than 0.

## Service life of bellows packing

Bellows material	Temperature				
	200°C	300°C	400°C	500°C	550°C
1.4541	100 000	40 000	28 000	7 000	not applicable
1.4571	90 000	34 000	22 000	13 000	8 000

Values specified in the table above show minimal guaranteed number of cycles with the valve full stroke when the bellows is fully lengthened and pressed. In regulation, when the valve

moves only in a portion of the stroke range at the inner centre of the valve, the service life of the bellows is many times longer then depending on concrete operating conditions.

## Procedure for designing of two-way valve

Given: medium water, 155°C, static pressure at piping spot 1000 kPa (10 bar),  $\Delta p_{DISP} = 80$  kPa (0,8 bar),  $\Delta p_{PIPELINE} = 15$  kPa (0,15 bar),  $\Delta p_{APPLIANCE} = 25$  kPa (0,25 bar), nominal flow rate  $Q_{NOM} = 8$  m<sup>3</sup>.h<sup>-1</sup>, minimal flow rate  $Q_{MIN} = 1,3$  m<sup>3</sup>.h<sup>-1</sup>.

$$\Delta p_{DISP} = \Delta p_{VALVE} + \Delta p_{APPLIANCE} + \Delta p_{PIPELINE}$$

$$\Delta p_{VALVE} = \Delta p_{DISP} - \Delta p_{APPLIANCE} - \Delta p_{PIPELINE} = 80 - 25 - 15 = 40 \text{ kPa (0,4 bar)}$$

$$Kv = \frac{Q_{NOM}}{\sqrt{\Delta p_{VALVE}}} = \frac{8}{\sqrt{0,4}} = 12,7 \text{ m}^3 \cdot \text{h}^{-1}$$

Precautionary additions for process tolerances (provided that flow rate Q was not oversized):

$$Kvs = (1,1 \text{ to } 1,3) \cdot Kv = (1,1 \text{ to } 1,3) \cdot 12,7 = 14 \text{ to } 16,5 \text{ m}^3 \cdot \text{h}^{-1}$$

Now we choose the nearest Kvs value from those available in our catalogue, i.e.  $Kvs = 16$  m<sup>3</sup>.h<sup>-1</sup>. This value corresponds to nominal size of DN 32. Then if we choose flanged execution PN 16, body made of spheroidal cast iron, with metal - PTFE seat sealing, packing PTFE and equal-percentage flow characteristic, we will get the following specification No.:

**RV 21x XXX 1423 R1 16/220-32**

x in the valve code above (21x) stands for valve execution (direct or reverse) and depends on type of used actuator which should be chosen in respect to demands of regulating system (type, producer, voltage, type of control, necessary torque or linear force, etc.)

## Determination of real pressure drop value of a chosen valve at fully open

$$\Delta p_{VENTIL H100} = \left( \frac{Q_{NOM}}{Kvs} \right)^2 = \left( \frac{8}{16} \right)^2 = 0,25 \text{ bar (25 kPa)}$$

The control valve's real pressure drop calculated this way shall be taken into account in a hydraulic calculation of regulating circuit.

Scheme of typical regulation loop with the application of two-way control valve

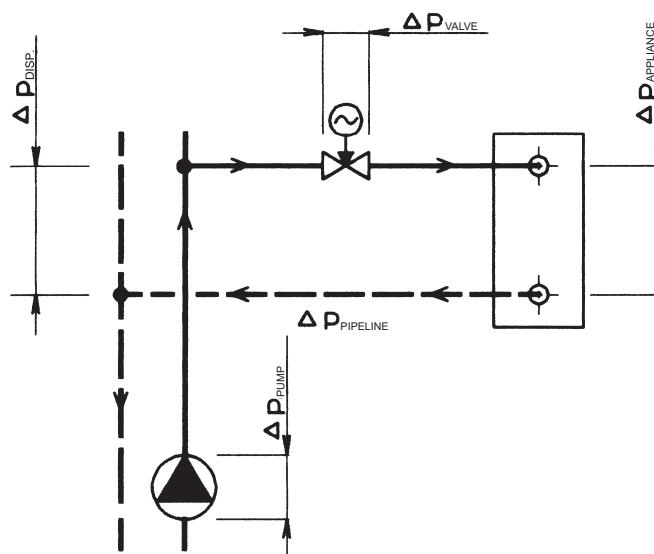

Remark: More detailed information on calculation and design of LDM control valves is mentioned in calculation instructions No. 01-12.0. Equations mentioned above apply in a simplified way to water. To reach optimum results, we recommend to use original calculation programme VALVES which is available on request free of charge.

## Determination of valve's real authority

$$a = \frac{\Delta p_{VALVE H100}}{\Delta p_{VALVE HO}} = \frac{12,3}{40} = 0,31$$

Value  $\underline{a}$  should be at least equal to 0,3. A chosen valve checking is then satisfactory.

**Caution:** the valve's authority calculation should be related to a valve pressure difference in its closed position i.e. disposition pressure value in a branch  $\Delta p_{AVAIL}$  when flow rate is zero, not to a pressure value of a pump  $\Delta p_{PUMP}$ , because, due to pipeline circuit pressure drops up to the spot where the regulating branch is connected, the following equation applies:  $\Delta p_{AVAIL} < \Delta p_{PUMP}$ . In such cases we consider for simplicity the following:  $\Delta p_{AVAIL H100} = \Delta p_{AVAIL HO} = \Delta p_{DISP}$ .

## Checking of rangeability

We carry out the same checking for minimal flow rate  $Q_{MIN} = 1,3$  m<sup>3</sup>.h<sup>-1</sup>. The following differential pressure values correspond to the min. flow rate:  $\Delta p_{PIPELINE QMIN} = 0,40$  kPa,  $\Delta p_{APPLIANCE QMIN} = 0,66$  kPa.  $\Delta p_{VALVE QMIN} = 80 - 0,4 - 0,66 = 78,94 = 79$  kPa.

$$Kv_{MIN} = \frac{Q_{MIN}}{\sqrt{\Delta p_{VALVE QMIN}}} = \frac{1,3}{\sqrt{0,79}} = 1,46 \text{ m}^3 \cdot \text{h}^{-1}$$

Necessary rangeability value

$$r = \frac{Kvs}{Kv_{MIN}} = \frac{16}{1,46} = 11$$

shall be lower than mentioned rangeability value of  $r = 50$ . Checking is then satisfactory.

## Selection of suitable flow characteristic

On the basis of calculated values  $Kv_{NOM}$  and  $Kv_{MIN}$ , it is possible to read the appropriate stroke values from the graph for individual types of flow characteristics of the valve and choose the most suitable one accordingly. Here we have  $h_{NOM} = 96\%$   $h_{MIN} = 41\%$  for equal-percentage characteristic. In that case, LDMspline® flow characteristic is more suitable (93% and 30% of the stroke). It corresponds to the following specification code:

**RV 21x XXX 1423 S1 16/220-32**

## Procedure for designing of three-way valve

Given: medium water, 90°C, static pressure at piping spot 1000 kPa (10 bar),  $\Delta p_{\text{PUMP2}} = 40 \text{ kPa}$  (0,4 bar),  $\Delta p_{\text{PIPELINE}} = 10 \text{ kPa}$  (0,1bar),  $\Delta p_{\text{APPLIANCE}} = 20 \text{ kPa}$  (0,2 bar), flow rate  $Q_{\text{NOM}} = 7 \text{ m}^3 \cdot \text{h}^{-1}$

$$\Delta p_{\text{PUMP2}} = \Delta p_{\text{VALVE}} + \Delta p_{\text{APPLIANCE}} + \Delta p_{\text{PIPELINE}}$$

$$\Delta p_{\text{VALVE}} = \Delta p_{\text{PUMP2}} - \Delta p_{\text{APPLIANCE}} - \Delta p_{\text{PIPELINE}} = 40 - 20 - 10 = 10 \text{ kPa} (0,1 \text{ bar})$$

$$Kv = \frac{Q_{\text{NOM}}}{\sqrt{\Delta p_{\text{VALVE}}}} = \frac{7}{\sqrt{0,1}} = 22,1 \text{ m}^3 \cdot \text{h}^{-1}$$

Precautionary additions for process tolerances (provided that flow rate Q was not oversized):

$$Kvs = (1,1 \text{ to } 1,3) \cdot Kv = (1,1 \text{ to } 1,3) \cdot 22,1 = 24,3 \text{ to } 28,7 \text{ m}^3 \cdot \text{h}^{-1}$$

Now we choose the nearest Kvs value from those available in our catalogue, i.e.  $Kvs = 25 \text{ m}^3 \cdot \text{h}^{-1}$ . This value corresponds to nominal size of DN 40. Then if we choose flanged execution PN 16, body made of spheroidal cast iron, with metal - PTFE seat sealing, packing PTFE and equal-percentage flow characteristic, we will get the following specification No.:

**RV 21x XXX 1413 L1 16/140-40**

x in the valve code above (21x) stands for valve execution (direct or reverse) and depends on type of used actuator which should be chosen in respect to demands of regulating system (type, producer, voltage, type of control, necessary torque or linear force, etc.)

## Determination of real pressure drop value of a chosen valve at fully open

$$\Delta p_{\text{VALVE H100}} = \left( \frac{Q_{\text{NOM}}}{Kvs} \right)^2 = \left( \frac{7}{25} \right)^2 = 0,08 \text{ bar} (8 \text{ kPa})$$

The control valve's real pressure drop calculated this way shall be taken into account in a hydraulic calculation of regulating circuit.

**Caution:** To ensure reliable function of three-way valves, the most important condition is to keep minimum available pressure difference between A and B ports. Three-way valves are capable to manage even high pressure difference between A and B ports but valve's flow characteristic deformats then and so regulation properties deteriorate. So if in doubt about pressure difference value between those two ports (e.g. when three-way valve is piped directly into primary side without pressure separation), we recommend to use a two-way valve in combination with a primary-secondary side short cut to ensure a reliable regulation. The authority of A-AB way of three-way valve is, providing a constant flow rate in appliance circuit, the following:

$$a = \frac{\Delta p_{\text{VALVE H100}}}{\Delta p_{\text{VALVE H0}}} = \frac{8}{8} = 1,$$

which means that the behaviour of flow in A-AB way corresponds to ideal flow curve of the valve. In that case there are Kvs values in both ports the same with linear characteristic i.e. the total flow is nearly constant.

A combination of equal-percentage characteristic in A port and linear characteristic in B port shall be selected in those cases when loading of A port with differential pressure against B port cannot be avoided or when the primary side parametres are too high.

Scheme of a typical regulation loop with the application of a three-way mixing control valve

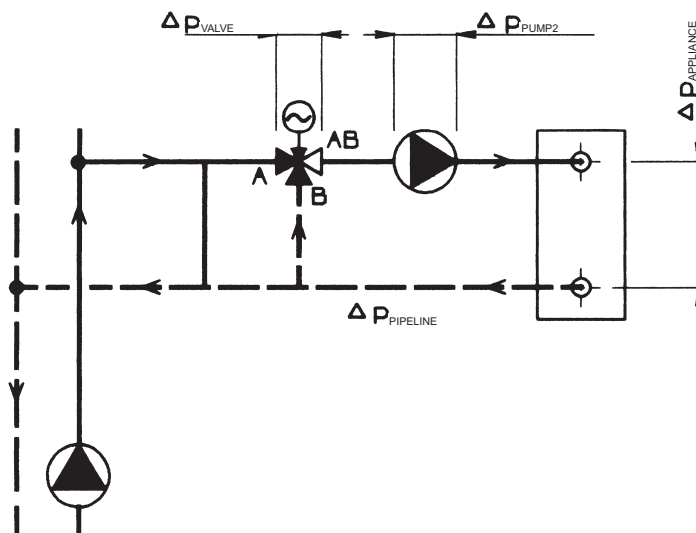

**Remark:** More detailed information on calculation and design of LDM control valves is mentioned in calculation instructions No. 01-12.0. Equations mentioned above apply in a simplified way to water. To reach optimum results, we recommend to use original calculation programme VALVES which is available on request free of charge.

# RV 102 C RV 103 C



## Control valves DN 15 - 50, PN 16 with Johnson Controls actuators

### Description

Control valves series RV 102 are two-way or three-way valves with internal threaded connection. Valve body is made of brass. Control valves series RV 103 are two-way or three-way valves with flanged connection. Valve body is made of grey cast iron. Valves are optionally manufactured in the following executions:

- three-way control valve
- two-way, reverse, control valve
- two-way, angular, control valve

Valves RV 102 C and RV 103 C are especially designed for Johnson Controls actuators.

### Application

Valves are designed for application in heating, ventilation or air conditioning systems for maximal temperature 150°C. Max. permissible working pressures according to ČSN 13 0010, see page 38 of this catalogue.

### Process media

Valve series RV 102 and RV 103 are designed to regulate the flow and pressure of liquids, gases and vapours without abrasive particles e.g. water, low-pressure steam (it applies to RV 102 only), air and other media compatible with material of the valve inner parts. Medium acidity and alkalinity should not exceed range of pH 4.5 to 9.5.

To ensure reliable regulation, producer recommends to pipe a strainer in front of the valve into pipeline.

### Installation

The valve is to be piped the way so that the direction of medium flow will coincide with the arrows on the body (inlet ports A, B and outlet port AB).

In flow-diverting valves, the process medium flow is reversed (inlet port AB and outlet ports A, B).

Valve can be installed in any position except position when the actuator is under the valve body.

### Technical data

Series	RV 102	RV 103
Type of valve	Three-way control valve Two-way, reverse, control valve	
Nominal size range	DN 15 - 50	
Nominal pressure	PN 16	
Body material	Brass 42 3135	Grey cast iron EN-JL 1040
Plug material	Brass 42 3234	
Operating temperature range	-5 to 150°C	
Face to face dimensions	Acc. to DIN 3202 - M4	Acc. to DIN 3202 - F1
Connection	Internal threaded coupling	Flange type B1 (raised-faced) Acc. to ČSN-EN 1092-1 (4/2002)
Type of plug	V-ported plug	
Flow characteristic	Linear; equal-percentage (applicable to basic Kvs values)	
Kvs values	0.6 to 40 m <sup>3</sup> /hour	
Leakage rate	Class III. acc. to ČSN 1349 (5/2001) (<0.05 % of Kvs) value in straight way	
Rangeability r	50 : 1	
Packing	O - ring EPDM	

## Kvs values and differential pressures

$\Delta p_{max}$  value is the valve maximal differential pressure when reliable opening and closing can be guaranteed. Because of seat and plug service life, it is recommended so that

permanent differential pressure would not exceed 0.6 MPa for valves RV 102 and 0.4 MPa for valves RV 103.

For further information on actuating, see actuators' catalogue sheets		Actuating (actuator)					VA-77xx-100x	VA-7810-xxx-11
		Marking in valve spec. No.					ECM	ECN
		Linear force					500 N $\pm$ 20%	1000 N $\pm$ 20%
		Kvs [m <sup>3</sup> /hour]					$\Delta p_{max}$	$\Delta p_{max}$
DN	H	1	2	3	4	5	MPa	MPa
15	10	4.0	2.5	1.6	1.0	0.6	1.60	1.60
20		6.3	4.0	2.5	---	---	1.07	1.60
25		10.0	6.3	4.0	---	---	0.69	1.18
32	16	16.0	10.0	6.3	---	---	0.42	0.73
40		25.0	16.0	10.0	---	---	0.27	0.47
50		40.0	25.0	16.0	---	---	0.15	0.28

## Dimensions and weights for the type RV 102

DN	C	L <sub>1</sub>	L <sub>2</sub>	L <sub>3</sub>	V <sub>1</sub>	V <sub>2</sub>	S	H	D	m
		mm	mm	mm	mm	mm	mm	mm	mm	kg
15	G 1/2	85	9	12	43	25	27	10	1/4" UNF	0.55
20	G 3/4	95	11	14	48	25	32			0.65
25	G 1	105	12	16	53	25	41			0.80
32	G 1 1/4	120	14	18	66	35	50	16	1/4" UNF	1.40
40	G 1 1/2	130	16	20	70	35	58			2.00
50	G 2	150	18	22	80	42	70			2.95

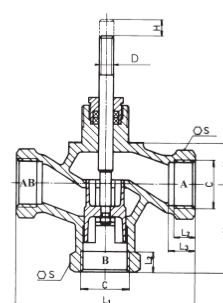

## Dimensions and weights for the type RV 103

DN	D <sub>1</sub>	D <sub>2</sub>	D <sub>3</sub>	n x d	a	f	L <sub>1</sub>	V <sub>1</sub>	V <sub>2</sub>	H	D	m			
	mm	mm	mm	mm	mm	mm	mm	mm	mm	mm	mm	kg			
15	95	65	45	4x14	16	2	130	65	25	10	1/4" UNF	3.2			
20	105	75	58									150	75	25	4.3
25	115	85	68									180	80	25	5.5
32	140	100	78	4x18	18	3	200	100	35	16	1/4" UNF	7.7			
40	150	110	88									230	115	42	8.5
50	165	125	102									230	115	42	11.9

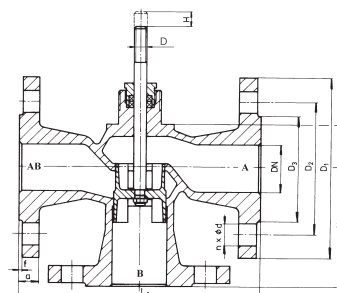

## Valve complete specification No. for ordering

		XX	X X X	X X X	X X	X X	- XX	/	XXX	- XX
1. Type of valve	Control valve	RV								
2. Series	Valves made of brass		1 0 2							
	Valves made of grey cast iron		1 0 3							
3. Actuating	Electric actuators			E						
	Electric actuators VA-77xx-100x			E C M						
	Electric actuators VA-7810-xxx-11			E C N						
4. Design	Straight, two-way, threaded valves				1					
	Angle, two-way, threaded valves	Applicable to RV 102			2					
	Mixing (diverting), three-way, threaded valves				3					
	Straight, two-way, flanged valves				4					
	Angle, two-way, flanged valves	Applicable to RV 103			5					
	Mixing (diverting), three-way, flanged valves				6					
5. Body material	Grey cast iron				3					
	Brass				5					
6. Flow characteristic	Linear					1				
	Equal-percentage <sup>1)</sup>					2				
7. Nominal Kvs value	Column No. acc. to Kvs values table					X				
8. Nominal pressure PN	PN 16						16			
9. Max. operating temperature °C									150	
10. Nominal size	DN									XX

**Ordering example:** Three-way control valve DN 25, PN 16 with electric actuator VA 7740-1003, body material: brass, connection: internal thread G 1, linear flow characteristic, Kvs = 10 m<sup>3</sup> /hour is specified as follows: **RV 102 ECM 3511 16/140-25.**

## 200 line

### RV 2x0 C



**Control valve  
DN 50 - 150, PN 16 and 40  
with Johnson Controls actuators**

## Description

Control valves RV 210, RV 220 and RV 230 (further only RV 2x0) are single-seated valves designed for regulation and shut-off of process medium flow. In regard of used actuators, the valves are suitable for regulation at low and medium high differential pressures. Flow characteristics, Kvs values and leakage rates correspond to international standards.

Valves RV 2x0 C are especially designed for electromechanic actuators of Johnson Controls.

## Application

These valves have a wide range of application in heating, ventilation, power generation and chemical processing industries. Valve body can be optionally made of spheroidal cast iron, cast steel and austenitic stainless steel according to operating conditions.

The materials selected correspond to recommendations stipulated by ČSN-EN 1503-1 (1/2002) (steels) and ČSN-EN 1503-3 (1/2002) (cast). The maximum operating pressures for different materials are specified in the table on page 38 of this catalogue.

## Process media

Valves series RV 2x0 are designed for regulation and shut-off of flow and pressure of liquids, gases and vapours without abrasive particles e.g. water, steam, air and other media compatible with material of the valve inner parts. The usage of the valve made of spheroidal cast iron (RV210) for steam is limited by the following parameters. The steam must be superheated (its dryness at valve outlet  $x_2 \geq 0,98$ ) and inlet pressure  $p_1 \leq 0,4$  MPa when differential pressure is of above-critical value, and  $p_1 \leq 1,6$  MPa when differential pressure is of under-critical value. In case these two conditions are not kept, it is necessary to use the valve made of cast steel (RV 220). To ensure a reliable regulation, the producers recommends to pipe a strainer in front of the valve into pipeline or ensure in any other way that process medium does not contain abrasive particles or impurities.

## Installation

The valve is to be piped the way so that the direction of medium flow will coincide with the arrows on the body.

The valve can be installed in any position except position when the actuator is under the valve body. When medium temperature exceeds 150°C, it is necessary to protect the actuator against glowing heat from the pipeline e.g. by the means of proper insulating of the pipeline and valve or by tilting the valve away from the heat radiation.

## Technical data

Series	RV 210	RV 220	RV 230
Type of valve	Two-way, single-seated, control valve		
Nominal size range	DN 15 to 150		
Nominal pressure	PN 16, PN 40		
Body material	Spheroidal cast iron EN-JS 1025 (EN-GJS-400-10-LT)	Cast steel 1.0619 (GP240GH) 1.7357 (G17CrMo5-5)	Stainless steel 1.4581 (GX5CrNiMoNb19-11-2)
Seat material: DN 15 - 50	1.4028 / 17 023.6	1.4028 / 17 023.6	1.4571 / 17 347.4
DIN W.Nr./ČSN DN 65	1.4027 / 42 2906.5	1.4027 / 42 2906.5	1.4581 / 42 2941.4
Plug material: DN 15 - 65	1.4021 / 17 027.6	1.4021 / 17 027.6	1.4571 / 17 347.4
DIN W.Nr./ČSN	1.4027 / 42 2906.5	1.4027 / 42 2906.5	1.4581 / 42 2941.4
Operating temperature range	-20 to 300°C	-20 to 500°C	-20 to 400°C
Face to face dimensions	Line 1 acc. to ČSN-EN 558-1 (3/1997)		
Flanges	Acc. to ČSN-EN 1092-1 (4/2002)		
Flange face	Type B1 (raised-faced) or Type F (female) acc. to ČSN-EN 1092-1 (4/2002)		
Type of plug	V-ported, parabolic, perforated		
Flow characteristic	Linear, equal-percentage, LDMspline <sup>®</sup> , parabolic		
Kvs value	0.4 to 63 m <sup>3</sup> /hour		
Leakage rate	Class III. acc. to ČSN-EN 1349 (5/2001) (<0.1% Kvs) for c. valves with metal-metal seat sealing Class IV. acc. to ČSN-EN 1349 (5/2001) (<0.01% Kvs) for c. valves with metal-PTFE seat sealing		
Rangeability r	50 : 1		
Packing	O - ring EPDM $t_{max}=140^{\circ}C$ , DRSpack <sup>®</sup> (PTFE) $t_{max}=260^{\circ}C$ , Exp. graphite, bellows $t_{max}=500^{\circ}C$		

Remark: For low operating temperatures (-200 to +250°C), it is possible to supply the valve RV 231 with body material made of 1.4308 (cast stainless steel).



## Kvs and differential pressure values with electromechanic actuators

$\Delta p_{max}$  value is the valve max. differential pressure when open - close function is always guaranteed. In regard of service life of seat and plug, it is recommended so that

differential pressure would not exceed 1.6 MPa. Otherwise it is suitable to use perforated plug or sealing surfaces of seat and plug with a hard metal overlay.

For further information on actuation, see actuator's catalogue sheets		Actuating (actuator)			RA 3xxx-722x	FA 22xx-751x FA 25xx-751x	RA 3xxx-732x	FA 33xx-741x				
		Marking in valve specification No			ECI	ECK	ECI	ECL				
		Linear force			1800 N		2300 N		3000 N		6000 N	
		Kvs [m <sup>3</sup> /hour]			$\Delta p_{max}$		$\Delta p_{max}$		$\Delta p_{max}$		$\Delta p_{max}$	
DN	H	1	2	3	metal PTFE		metal PTFE		metal PTFE		metal PTFE	
50	25	40.0	25.0	16.0	0.33	0.52	0.54	0.74	---	---	---	---
65		63.0	40.0	25.0	0.16	0.32	0.29	0.45	---	---	---	---
80	42	100.0	63.0	40.0	---	---	---	---	0.19	0.32	0.73	0.86
100		160.0	100.0	63.0	---	---	---	---	0.10	0.21	0.45	0.56
125		250.0	160.0	100.0	---	---	---	---	0.05	0.13	0.27	0.36
150		360.0	250.0	160.0	---	---	---	---	0.02	0.09	0.18	0.25

## Kvs and differential pressure values with pneumatic actuators

$\Delta p_{max}$  value is the valve max. differential pressure when open - close function is always guaranteed. In regard of service life of seat and plug, it is recommended so that

differential pressure would not exceed 1.6 MPa. Otherwise it is suitable to use perforated plug or sealing surfaces of seat and plug with a hard metal overlay.

For further information on actuation, see actuator's catalogue sheets		Pneumatic actuator		PA-2000												
		Spec. No. of actuator		PA-2xxx-3312	PA-2xxx-3327	PA-2xxx-3712	PA-2xxx-3727	PA-2xxx-3612	PA-2xxx-3627							
		Fail-safe action		direct		indirect		direct		indirect						
		Spring range [bar]		0,2 - 0,5		0,7 - 1,0		0,2 - 0,5		0,7 - 1,0						
		Spring setting [bar]		0,2		0,7		0,2		0,7						
		Feeding pressure [bar]		1,6		1,2		1,6		1,2						
		Mark in valve spec. No		PCB												
		Linear force		3300 N		2100 N		6600 N		4200 N		6600 N		4200 N		
		Kvs [m <sup>3</sup> /hour]		$\Delta p_{max}$		$\Delta p_{max}$		$\Delta p_{max}$		$\Delta p_{max}$		$\Delta p_{max}$		$\Delta p_{max}$		
DN	H	1	2	3	metal PTFE		metal PTFE		metal PTFE		metal PTFE		metal PTFE		metal PTFE	
50	25	40.0	25.0	16.0	0.97	1.16	0.46	0.65	2.37	2.57	1.35	1.54	---	---	---	---
65		63.0	40.0	25.0	0.55	0.71	0.24	0.39	1.41	1.56	0.79	0.94	---	---	---	---
80	42	100.0	63.0	40.0	---	---	---	---	---	---	---	---	0.84	0.97	0.41	0.54
100		160.0	100.0	63.0	---	---	---	---	---	---	---	---	0.52	0.63	0.24	0.35
125		250.0	160.0	100.0	---	---	---	---	---	---	---	---	0.32	0.41	0.14	0.22
150		360.0	250.0	160.0	---	---	---	---	---	---	---	---	0.21	0.28	0.08	0.16

Bellows packing can be used with V-ported plug only.

Perforated plug available only with Kvs values in shadowed frames with the following restrictions:

- Perforated plug with Kvs value acc. to column No. 2 available with linear or parabolic characteristic only.

Max. differential pressure  $\Delta p$  for valves PN 16 must be 1.6 Mpa.

metal - version with metal - metal seat sealing

PTFE - version with metal - PTFE seat sealing

Max. differential pressures specified in table apply to PTFE and O-ring packing.  $\Delta p_{max}$  for bellows must be consulted with the producer. It applies to graphite packing as well especially when required  $\Delta p$  value is close to max. values specified in table.

$\Delta p_{max}$  values are set for the most unfavourable pressure ratios on the valve PN 40, but in concrete cases the real  $\Delta p_{max}$  value can be higher than values specified in the table above.

## Dimensions and weights for the type RV 2x0

DN	PN 16					PN 40					PN 16, PN 40														
	D <sub>1</sub> mm	D <sub>2</sub> mm	D <sub>3</sub> mm	d mm	n	D <sub>1</sub> mm	D <sub>2</sub> mm	D <sub>3</sub> mm	d mm	n	D mm	f mm	D <sub>4</sub> mm	D <sub>5</sub> mm	L mm	V <sub>1</sub> mm	V <sub>2</sub> mm	<sup>#</sup> V <sub>2</sub> mm	V <sub>3</sub> mm	<sup>#</sup> V <sub>3</sub> mm	a mm	m <sub>1</sub> kg	m <sub>2</sub> kg	<sup>#</sup> m <sub>v</sub> kg	
50	165	125	102	18	4	165	125	102	18	4	50	2	54	12	230	85	150	338	216	404	20	14	21	4	
65	185	145	122		4 <sup>1)</sup>	185	145	122		18	65				290	93	150	338	216	404	22	18	27	4	
80	200	160	138		8	200	160	138		22	8				80	310	105	164	481	230	547	24	26	40	4.5
100	220	180	158		8	235	190	162		26	8				100	350	118	164	481	230	547	24	38	49	4.5
125	250	210	188		8	270	220	188		26	8				125	400	135	183	500	249	566	26	58	82	5
150	285	240	212	22	300	250	218	26	8	150	480	150	200	517	266	583	28	78	100	5					

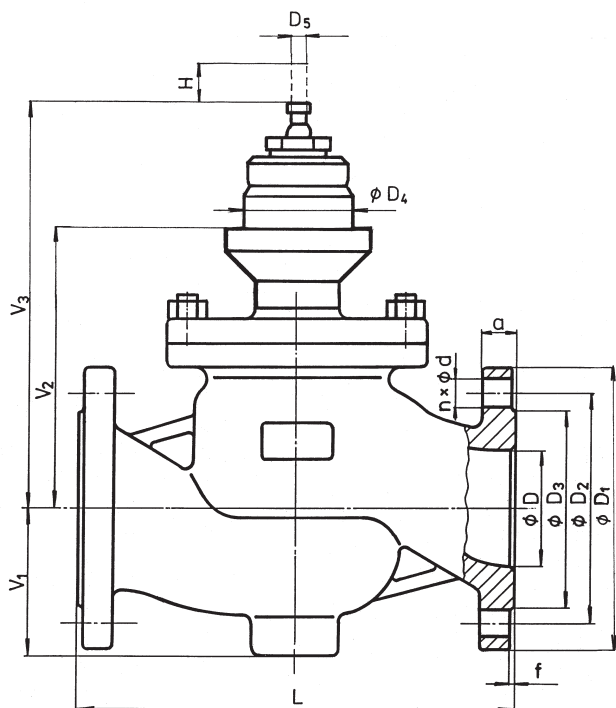

<sup>1)</sup> with regard of the standard previously in force, there is an option to have the number of connection bolts as stipulated in ČSN-EN 1092-1

<sup>#)</sup> - for valve with bellows packing

m<sub>v</sub> - weight to be added to weight of valve equipped with bellows packing

m<sub>1</sub> - for valves RV / HU 210

m<sub>2</sub> - for valves RV / HU 220 and RV / HU 230

## 200 line

### RV / HU 2x1 C



### Control valve and Fail-safe action valves DN 15 - 40, PN 16 and 40 with Johnson Controls actuators

#### Description

Control valves RV 211, RV 221 and RV 231 (further only RV 2x1) are single-seated valves designed for regulation and shut-off of process medium flow. In regard of used actuators, the valves are suitable for regulation at low and medium high differential pressures. Flow characteristics, Kvs values and leakage rates correspond to international standards.

Valves with a fail-safe action HU 2x1 have the same design as RV 2x1 with addition of increased seat sealing. Valves are equipped with fail-safe action actuators (valve closes upon power failure).

Valves RV 2x1 C are especially designed for electromechanic actuators of Johnson Controls.

#### Application

These valves have a wide range of application in heating, ventilation, power generation and chemical processing industries. Valve body can be optionally made of spheroidal cast iron, cast steel and austenitic stainless steel according to operating conditions.

The materials selected correspond to recommendations stipulated by ČSN-EN 1503-1 (1/2002) (steels) and ČSN-EN 1503-3 (1/2002) (cast). The maximum operating pressures for different materials are specified in the table on page 38 of this catalogue.

#### Process media

Valves series RV / HU 2x1 C are designed for regulation and for regulation and shut-off of flow and pressure of liquids, gases and vapours without abrasive particles e.g. Water, steam, air and other media compatible with material of the valve inner parts. The application of valves made of spheroidal cast iron (RV 211) for steam is limited by the following parameters: Steam must be superheated (its dryness  $x_1 \geq 0,98$ ) and inlet pressure  $p_1 \leq 0,4$  MPa when differential pressure is above-critical or  $p_1 \leq 1,6$  MPa when differential pressure is under-critical. In case these values are exceeded, it is necessary to use valve made of cast steel (RV 221). To ensure reliable regulation, producer recommends to pipe a strainer in front of the valve or ensure in any other way that medium will not contain abrasive particles or impurities.

#### Installation

The valve is to be piped the way so that the direction of medium flow will coincide with the arrows on the body.

The valve can be installed in any position except position when the actuator is under the valve body. When medium temperature exceeds 150°C, it is necessary to protect the actuator against glowing heat from the pipeline e.g. by the means of proper insulating of the pipeline and valve or by tilting the valve away from the heat radiation.

#### Technical data

Series	RV / HU 211	RV / HU 221	RV / HU 231
Type of valve	Single-seated, two-way control valve, reverse		
Nominal size range	DN 15 to 40		
Nominal pressure	PN 16, PN 40		
Body material	Spheroidal cast iron EN-JS 1025 (EN-GJS-400-10-LT)	Cast steel 1.0619 (GP240GH) 1.7357 (G17CrMo5-5)	Stainless steel 1.4581 (GX5CrNiMoNb19-11-2)
Seat material :	1.4028 / 17 023.6	1.4028 / 17 023.6	1.4571 / 17 347.4
Plug material :	1.4021 / 17 027.6	1.4021 / 17 027.6	17 347.4
Operating temperature range	-20 to 300°C	-20 to 300°C	-20 to 300°C
Face to face dimensions	Line 1 acc. to ČSN-EN 558-1 (3/1997)		
Flanges	Acc. to ČSN-EN 1092-1 (4/2002)		
Flange face	Type B1 (raised-faced) or Type F (female) acc. to ČSN-EN 1092-1 (4/2002)		
Type of plug	V-ported, parabolic, LDMspline <sup>®</sup> , perforated		
Flow characteristic	Linear, equal-percentage in AB - B way		
Kvs value	0.4 to 25 m <sup>3</sup> /hour		
Leakage rate	Class III. acc. to ČSN-EN 1349 (5/2001) (<0.1% Kvs) for c. valves with metal-metal seat sealing Class IV. acc. to ČSN-EN 1349 (5/2001) (<0.01% Kvs) for c. valves with metal-PTFE seat sealing		
Rangeability r	50 : 1		
Packing	O - ring EPDM $t_{max}=150^{\circ}C$ , DRSpac <sup>®</sup> (PTFE) $t_{max}=150^{\circ}C$ , Bellows $t_{max}=180^{\circ}C$		

Remark: For low operating temperatures (-200 to +250°C), it is possible to supply the valve RV / HU 231 with body material made of 1.4308 (cast stainless steel).

## Kvs and differential pressure values with electromechanic actuators

$\Delta p_{max}$  value is the valve max. differential pressure when open-close function is always guaranteed. In regard of service life of seat and plug, it is recommended so that permanent

differential pressure would not exceed 1.6 MPa. Otherwise it is suitable to use perforated plug or sealing surfaces of seat and plug with a hard metal overlay.

For further information on actuating, see actuator's catalogue sheet		Actuating (actuator)						VA-7810-xxx-12		RA-3xxx-712x		FA-10xx-210x	
		Marking in valve spec. No						ECN		ECI		HCJ	
		Linear force						1000 N $\pm$ 20%		1000 N		700 N	
		Kvs [m <sup>3</sup> /hour]						$\Delta p_{max}$		$\Delta p_{max}$		$\Delta p_{max}$	
DN	H	1	2	3	4	5	6	metal	PTFE	metal	PTFE	metal	PTFE
15	13	---	2.5 <sup>1)</sup>	1.6 <sup>1)</sup>	1.0 <sup>1)</sup>	0.6 <sup>1)</sup>	0.4 <sup>1)</sup>	4.00	---	4.00	---	4.00	---
15		4.0 <sup>1)</sup>	---	---	---	---	---	3.40	---	4.00	---	2.82	---
20		---	---	2.5 <sup>1)</sup>	1.6 <sup>1)</sup>	1.0 <sup>1)</sup>	0.6 <sup>1)</sup>	4.00	---	4.00	---	4.00	---
20		---	4.0 <sup>1)</sup>	---	---	---	---	3.40	---	4.00	---	2.82	---
20		6.3 <sup>1)</sup>	---	---	---	---	---	1.56	---	2.15	---	1.27	---
25		---	---	---	2.5 <sup>1)</sup>	1.6 <sup>1)</sup>	1.0 <sup>1)</sup>	4.00	---	4.00	---	4.00	---
25		10.0	6.3 <sup>2)</sup>	4.0 <sup>2)</sup>	---	---	---	0.88	1.29	1.24	1.65	0.69	1.11
32		---	---	---	4.0 <sup>1)</sup>	---	---	3.40	---	4.00	---	2.82	---
32		16.0	10.0	6.3 <sup>2)</sup>	---	---	---	0.45	0.77	0.67	0.99	0.34	0.66
40		25.0	16.0	10.0	---	---	---	0.23	0.49	0.38	0.63	0.16	0.42

## Kvs and differential pressure values with pneumatic actuators

$\Delta p_{max}$  value is the valve max. differential pressure when open-close function is always guaranteed. In regard of service life of seat and plug, it is recommended so that permanent

differential pressure would not exceed 1.6 MPa. Otherwise it is suitable to use perforated plug or sealing surfaces of seat and plug with a hard metal overlay.

For further information on actuating, see actuator's catalogue sheet		Pneumatic actuator						MP 8000			
		Spec. No. of actuator						MP822Cxx20		MP832Exx20	
		Fail-safe action						direct		indirect	
		Spring range [bar]						0,2 - 0,5		0,6 - 0,9	
		Spring setting [bar]						0,2		0,6	
		Feeding pressure [bar]						1,6		1,1	
		Mark in valve spec No						PCA			
		Linear force						1760 N		960 N	
		Kvs [m <sup>3</sup> /hour]						$\Delta p_{max}$		$\Delta p_{max}$	
DN	H	1	2	3	4	5	6	metal	PTFE	metal	PTFE
15	13	---	2.5 <sup>1)</sup>	1.6 <sup>1)</sup>	1.0 <sup>1)</sup>	0.6 <sup>1)</sup>	0.4 <sup>1)</sup>	4.00	---	4.00	---
15		4.0 <sup>1)</sup>	---	---	---	---	---	4.00	---	4.00	---
20		---	---	2.5 <sup>1)</sup>	1.6 <sup>1)</sup>	1.0 <sup>1)</sup>	0.6 <sup>1)</sup>	4.00	---	4.00	---
20		---	4.0 <sup>1)</sup>	---	---	---	---	4.00	---	4.00	---
20		6.3 <sup>1)</sup>	---	---	---	---	---	4.00	---	2.03	---
25		---	---	---	2.5 <sup>1)</sup>	1.6 <sup>1)</sup>	1.0 <sup>1)</sup>	4.00	---	4.00	---
25		10.0	6.3 <sup>2)</sup>	4.0 <sup>2)</sup>	---	---	---	2.63	3.04	1.17	1.58
32		---	---	---	4.0 <sup>1)</sup>	---	---	4.00	---	4.00	---
32		16.0	10.0	6.3 <sup>2)</sup>	---	---	---	1.51	1.83	0.63	0.95
40		25.0	16.0	10.0	---	---	---	0.92	1.17	0.35	0.60

1) parabolic plug

2) V-ported plug with linear characteristic, parabolic plug with equal-percentage, LDMspline® and parabolic characteristic.

Perforated plug available only with Kvs values in shadowed frames   with the following restrictions:

- Kvs values 2.5 to 1.0 m<sup>3</sup>/hour available with linear characteristic only.
- Perforated plug with Kvs value acc. to column No. 2 available with linear or parabolic characteristic only.

metal - version with metal - metal seat sealing

PTFE - version with metal - PTFE seat sealing

Bellows packing can be used with V-ported plug only.

Equal-percentage, LDMspline® and parabolic characteristic available on condition: Kvs value  $\geq$  1.0

Max. differential pressure  $\Delta p$  for valves PN 16 must be 1.6 Mpa. Max. differential pressures specified in table apply to PTFE and O-ring packing.  $\Delta p_{max}$  for bellows must be consulted with the producer.

## Dimension and weights for type RV / HU 2x1

DN	PN 16						PN 40						PN 16, PN 40											
	D <sub>1</sub> mm	D <sub>2</sub> mm	D <sub>3</sub> mm	d mm	n	a mm	D <sub>1</sub> mm	D <sub>2</sub> mm	D <sub>3</sub> mm	d mm	n	a mm	D mm	f mm	D <sub>4</sub> mm	D <sub>5</sub> mm	L mm	V <sub>1</sub> mm	V <sub>2</sub> mm	<sup>#</sup> V <sub>2</sub> mm	V <sub>3</sub> mm	<sup>#</sup> V <sub>3</sub> mm	m <sub>1</sub> kg	m <sub>2</sub> kg
15	95	65	45	14	4	16	95	65	45	14	16	15	2	54	10	130	68	98	---	169	---	4.5	5.5	---
20	105	75	58			18	105	75	58		18	20				150	68	98	---	169	---	5.5	6.5	---
25	115	85	68	18		115	85	68	18	25	160	85				103	238	174	309	6.5	8	3.5		
32	140	100	78	18		140	100	78	18	32	180	85				103	238	174	309	8	9.5	3.5		
40	150	110	88	18	150	110	88	18	40	200	85	103	238	174	309	9	11	3.5						

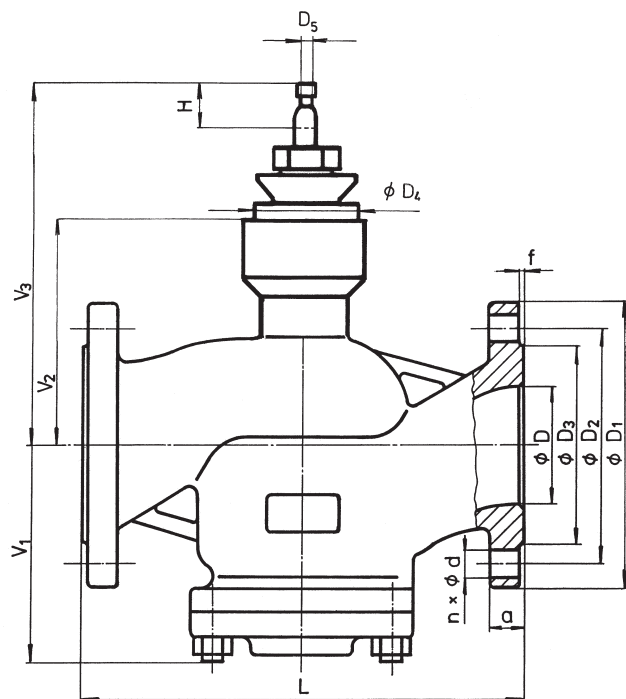

- <sup>#</sup> - for valve with bellows packing
- m<sub>v</sub> - weight to be added to weight of valve equipped with bellows packing
- m<sub>1</sub> - for valves RV / HU 211
- m<sub>2</sub> - for valves RV / HU 221 and RV / HU 231



### Control valves DN 50 - 150, PN 16 and 40 with Johnson Controls actuators

## Description

Control valves RV 212, RV 222 and RV 232 (further only RV 2x2) are single-seated valves with pressure-balanced plug designed for regulation and shut-off of process medium flow. In regard of used actuators, the valves are suitable for regulation at high differential pressures with low-linear-force-actuators. Flow characteristics, Kvs values and leakage rates correspond to international standards.

Valves RV 2x2 are especially designed for electromechanic actuators of Johnson Controls.

## Application

These valves have a wide range of application in heating, ventilation, power generation and chemical processing industries. Valve body can be optionally made of spheroidal cast iron, cast steel and austenitic stainless steel according to operating conditions.

The materials selected correspond to recommendations stipulated by ČSN-EN 1503-1 (1/2002) (steels) and ČSN-EN 1503-3 (1/2002) (cast). The maximum operating pressures for different materials are specified in the table on page 38 of this catalogue.

## Process media

Valves series RV 2x2 are designed for regulation of flow and pressure of liquids, gases and vapours without abrasive particles e.g. water, steam, air and other media compatible with material of the valve inner parts. The usage of the valve made of spheroidal cast iron (RV 212) for steam is limited by the following parameters. The steam must be superheated (its dryness at valve outlet  $x \geq 0,98$ ) and inlet pressure  $p \leq 0,4$  MPa when differential pressure is of above-critical value, and  $p \leq 1,6$  MPa when differential pressure is of under-critical value. In case these two conditions are not kept, it is necessary to use the valve made of cast steel (RV 222). To ensure a reliable regulation, the producers recommends to pipe a strainer in front of the valve into pipeline or ensure in any other way that process medium does not contain abrasive particles or impurities.

## Installation

The valve is to be piped the way so that the direction of medium flow will coincide with the arrows on the body.

The valve can be installed in any position except position when the actuator is under the valve body. When medium temperature exceeds 150°C, it is necessary to protect the actuator against glowing heat from the pipeline e.g. by the means of proper insulating of the pipeline and valve or by tilting the valve away from the heat radiation.

## Technical data

Series	RV 212	RV 222	RV 232
Type of valve	Two-way, single-seated control valve with pressure-balanced plug		
Nominal size range	DN 25 to 150		
Nominal pressure	PN 16, PN 40		
Body material	Spheroidal cast iron EN-JS 1025 (EN-GJS-400-10-LT)	Cast steel 1.0619 (GP240GH) 1.7357 (G17CrMo5-5)	Stainless steel 1.4581 (GX5CrNiMoNb19-11-2)
Seat material : DN 15 - 50	1.4028 / 17 023.6	1.4028 / 17 023.6	1.4571 / 17 347.4
DIN W.Nr./ČSN DN 65	1.4027 / 42 2906.5	1.4027 / 42 2906.5	1.4581 / 42 2941.4
Plug material : DN 15 - 65	1.4021 / 17 027.6	1.4021 / 17 027.6	1.4571 / 17 347.4
DIN W.Nr./ČSN	1.4027 / 42 2906.5	1.4027 / 42 2906.5	1.4581 / 42 2941.4
Operating temperature range	-20 to 260°C	-20 to 260°C	-20 to 260°C
Face to face dimensions	Line 1 acc. to ČSN-EN 558-1 (3/1997)		
Flanges	Acc. to ČSN-EN 1092-1 (4/2002)		
Flange face	Type B1 (raised-faced) or Type F (female) acc. to ČSN-EN 1092-1 (4/2002)		
Type of plug	V-ported, parabolic, perforated		
Flow characteristic	Linear, equal-percentage, LDMspline®, parabolic		
Kvs value	0.4 to 63 m <sup>3</sup> /hour		
Leakage rate	Class III. acc. to ČSN-EN 1349 (5/2001) (<0.1% Kvs) for c. valves with metal-metal seat sealing Class IV. acc. to ČSN-EN 1349 (5/2001) (<0.01% Kvs) for c. valves with metal-PTFE seat sealing		
Rangeability r	50 : 1		
Packing	O - ring EPDM t <sub>max</sub> =140°C, DRSpack® (PTFE) t <sub>max</sub> =260°C, Exp. graphite, bellows t <sub>max</sub> =500°C		

Remark: For low operating temperatures (-200 to +250°C), it is possible to supply the valve RV 232 with body material made of 1.4308 (cast stainless steel).

## Kvs and differential pressure values with electromechanic actuators

$\Delta p_{max}$  value is the valve max. differential pressure when open-close function is always guaranteed. In regard of service life of seat and plug, it is recommended so that permanent

differential pressure would not exceed 1.6 MPa. Otherwise it is suitable to use perforated plug or sealing surfaces of seat and plug with a hard metal overlay.

For more info on actuating, see actuators' data sheets		Actuating (actuator)		RA-3xxx-722x		FA-22xx-751x FA-25xx-751x		RA-3xxx-732x		FA-23xx-741x FA-26xx-741x		FA-33xx-741x		
		Mark.		ECI		ECK		ECI		ECK		ECL		
		Lin. force		1800 N		2300 N		3000 N		2200 N		6000 N		
DN	H	Kvs [m <sup>3</sup> /hour]			$\Delta p_{max}$		$\Delta p_{max}$		$\Delta p_{max}$		$\Delta p_{max}$		$\Delta p_{max}$	
		1	2	3	metal	PTFE	metal	PTFE	metal	PTFE	metal	PTFE	metal	PTFE
50	25	32.0	25.0	16.0	4.00 (4.00)	4.00 (4.00)	4.00 (4.00)	4.00 (4.00)	---	---	---	---	---	---
65		50.0	40.0	25.0	4.00 (3.40)	4.00 (4.00)	4.00 (4.00)	4.00 (4.00)	---	---	---	---	---	---
80	42	100.0	63.0	40.0	---	---	---	---	4.00 (4.00)	4.00 (4.00)	4.00 (3.30)	4.00 (4.00)	4.00 (4.00)	4.00 (4.00)
100		160.0	100.0	63.0	---	---	---	---	4.00 (3.90)	4.00 (4.00)	4.00 (2.30)	4.00 (3.90)	4.00 (4.00)	4.00 (4.00)
125		250.0	160.0	100.0	---	---	---	---	4.00 (2.70)	4.00 (4.00)	2.50 (1.40)	4.00 (3.00)	4.00 (4.00)	4.00 (4.00)
150		360.0	250.0	160.0	---	---	---	---	3.00 (1.90)	4.00 (3.60)	1.30 (0.80)	3.90 (2.50)	4.00 (4.00)	4.00 (4.00)

## Kvs and differential pressure values with pneumatic actuators

$\Delta p_{max}$  value is the valve max. differential pressure when open-close function is always guaranteed. In regard of service life of seat and plug, it is recommended so that permanent

differential pressure would not exceed 1.6 MPa. Otherwise it is suitable to use perforated plug or sealing surfaces of seat and plug with a hard metal overlay.

For more info on actuating, see actuators' data sheets		Pneumatic actuator			PA 2000							
		Specif. No. of actuator			PA-2xxx-3312		PA-2xxx-3327		PA-2xxx-3712		PA-2xxx-3727	
		Actuator function			fail to open		fail to close		fail to open		fail to close	
		Spring range [bar]			0,2 - 0,5		0,7 - 1,0		0,2 - 0,5		0,7 - 1,0	
		Spring setting [bar]			0,2		0,7		0,2		0,7	
		Feeding pressure [bar]			1,6		1,2		1,6		1,2	
		Mark in valve spec. No.			PCB							
		Linear force			3300 N		2100 N		6600 N		4200 N	
DN	H	Kvs [m <sup>3</sup> /hour]			$\Delta p_{max}$		$\Delta p_{max}$		$\Delta p_{max}$		$\Delta p_{max}$	
		1	2	3	metal	PTFE	metal	PTFE	metal	PTFE	metal	PTFE
50	25	32.0	25.0	16.0	4.00 (4.00)	4.00 (4.00)	4.00 (4.00)	4.00 (4.00)	4.00 (4.00)	4.00 (4.00)	4.00 (4.00)	4.00 (4.00)
65		50.0	40.0	25.0	4.00 (4.00)	4.00 (4.00)	4.00 (4.00)	4.00 (4.00)	4.00 (4.00)	4.00 (4.00)	4.00 (4.00)	4.00 (4.00)

For more info on actuating, see actuators' data sheets		Pneumatic actuator			PA 2000							
		Specif. No. of actuator			PA-2xxx-3612				PA-2xxx-3627			
		Actuator function			fail to open				fail to close			
		Spring range [bar]			0,2 - 0,5				0,7 - 1,0			
		Spring setting [bar]			0,2				0,7			
		Feeding pressure [bar]			1,6				1,2			
		Mark in valve spec. No.			PCB							
		Linear force			6600 N				4200 N			
DN	H	Kvs [m <sup>3</sup> /hour]			$\Delta p_{max}$				$\Delta p_{max}$			
		1	2	3	metal		PTFE		metal		PTFE	
80	42	100.0	63.0	40.0	4.00	(4.00)	4.00	(4.00)	4.00	(4.00)	4.00	(4.00)
100		160.0	100.0	63.0	4.00	(4.00)	4.00	(4.00)	4.00	(4.00)	4.00	(4.00)
125		250.0	160.0	100.0	4.00	(4.00)	4.00	(4.00)	4.00	(4.00)	4.00	(4.00)
150		360.0	250.0	160.0	4.00	(4.00)	4.00	(4.00)	4.00	(3.60)	4.00	(4.00)

Perforated plug available only with Kvs values in shadowed frames with the following restrictions:

- Perforated plug with Kvs value acc. to column No. 2 available with linear or parabolic flow characteristic only.

Max. differential pressures specified in table apply to PTFE and O-ring packing.  $\Delta p_{max}$  for bellows must be consulted with the producer.

metal - version with metal - metal seat sealing  
PTFE - version with metal - PTFE seat sealing

(xx) -  $\Delta p_{max}$  values specified in parentheses apply to perforated plug

Max. diff. pressure  $\Delta p$  for valves PN 16 must be 1.6 MPa.

## Dimensions and weight for the type RV 2x2

DN	PN 16					PN 40					PN 16, PN 40														
	D <sub>1</sub> mm	D <sub>2</sub> mm	D <sub>3</sub> mm	d mm	n	D <sub>1</sub> mm	D <sub>2</sub> mm	D <sub>3</sub> mm	d mm	n	D mm	f mm	D <sub>4</sub> mm	D <sub>5</sub> mm	L mm	V <sub>1</sub> mm	V <sub>2</sub> mm	<sup>#</sup> V <sub>2</sub> mm	V <sub>3</sub> mm	<sup>#</sup> V <sub>3</sub> mm	a mm	m <sub>1</sub> kg	m <sub>2</sub> kg	<sup>#</sup> m <sub>v</sub> kg	
50	165	125	102	18	4	165	125	102	18	4	50	2	54	12	230	85	150	338	216	404	20	14.5	21	4	
65	185	145	122		4 <sup>1)</sup>	185	145	122		18	4				65	290	93	150	338	216	404	22	18.5	27	4
80	200	160	138	8	8	200	160	138	22	8	80	2	54	13.8	310	105	164	481	230	547	24	27.5	42	4.5	
100	220	180	158			235	190	162			22				100	350	118	164	481	230	547	24	39	50	4.5
125	250	210	188			270	220	188			26				125	400	135	183	500	249	566	26	60	84	5
150	285	240	212			300	250	218							26	150	480	150	200	517	266	583	28	81	103

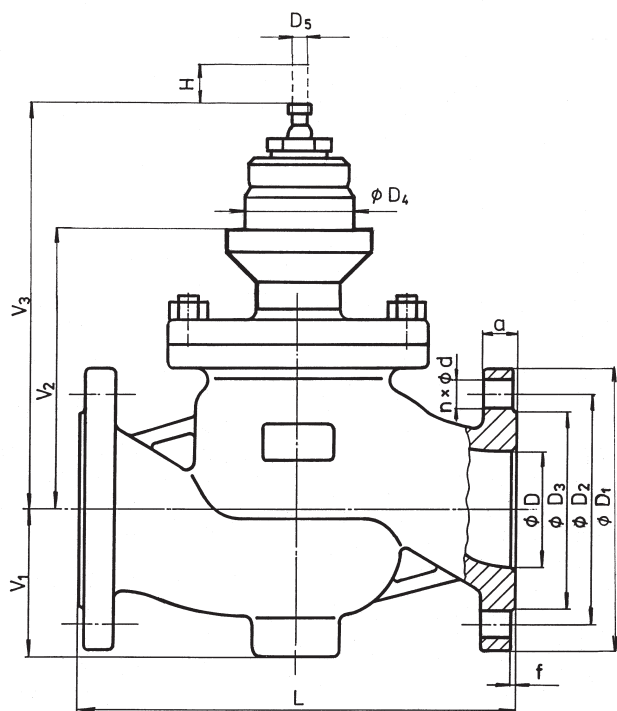

<sup>1)</sup> with regard of the standard previously in force, there is an option to have the number of connection bolts as stipulated in ČSN-EN 1092-1

<sup>#)</sup> - for valve with bellows packing

m<sub>v</sub> - weight to be added to weight of valve equipped with bellows packing

m<sub>1</sub> - for valves RV / HU 212

m<sub>2</sub> - for valves RV / HU 222 and RV / HU 232





### Control valves DN 15 - 150, PN 16 and 40 with Johnson Controls actuators

#### Description

Control valves RV 214, RV 224 and RV 234 (further only RV 2x4) are three-way valves with mixing or flow-diverting function. In regard of used actuators, the valves are suitable for regulation at low and medium high differential pressures in a diversity of operating conditions. Flow characteristics, Kvs values and leakage rates correspond to international standards.

Valves RV 2x4 are especially designed for electromechanic actuators of Johnson Controls.

#### Application

These valves have a wide range of application in heating, ventilation, power generation and chemical processing industries. Valve body can be optionally made of spheroidal cast iron, cast steel and austenitic stainless steel according to operating conditions.

The materials selected correspond to recommendations stipulated by ČSN-EN 1503-1 (1/2002) (steels) and ČSN-EN 1503-3 (1/2002) (cast). The maximum operating pressures for different materials are specified in the table on page 38 of this catalogue.

#### Process media

Valves series RV 2x4 are designed for regulation of flow and pressure of liquids, gases and vapours without abrasive particles e.g. water, steam, air and other media compatible with material of the valve inner parts. The usage of the valve made of spheroidal cast iron (RV 214) for steam is limited by the following parameters. The steam must be superheated (its dryness at valve outlet  $x_2 \geq 0,98$ ) and inlet pressure  $p_1 \leq 0,4$  MPa when differential pressure is of above-critical value, and  $p_1 \leq 1,6$  MPa when differential pressure is of under-critical value. In case these two conditions are not kept, it is necessary to use the valve made of cast steel (RV 224). To ensure a reliable regulation, the producer recommends to pipe a strainer in front of the valve into pipeline or ensure in any other way that process medium does not contain abrasive particles or impurities.

#### Installation

When the valve is used as mixing, it must be piped the way so that direction of process medium flow will coincide with the arrows on the body (inlet ports A, B and outlet port AB). When the valve is used as diverting, process medium flows through common valve port AB and split streams leave through valve ports A and B). The valve can be installed in any position except position when the actuator is under the valve body. When medium temperature exceeds 150°C, it is necessary to protect the actuator against glowing heat from the pipeline; e.g. by the means of proper insulating of the pipeline and valve or by tilting the valve away from the heat radiation.

#### Technical data

Series	RV 214	RV 224	RV 234
Type of valve	Three-way control valve		
Nominal size range	DN 15 to 150		
Nominal pressure	PN 16, PN 40		
Body material	Spheroidal cast iron EN-JS 1025 (EN-GJS-400-10-LT)	Cast steel 1.0619 (GP240GH) 1.7357 (G17CrMo5-5)	Stainless steel 1.4581 (GX5CrNiMoNb19-11-2)
Seat material :	DN 15 - 50 1.4028 / 17 023.6	1.4028 / 17 023.6	1.4571 / 17 347.4
DIN W.Nr./ČSN	DN 65 - 150 1.4027 / 42 2906.5	1.4027 / 42 2906.5	1.4581 / 42 2941.4
Plug material :	DN 15 - 65 1.4021 / 17 027.6	1.4021 / 17 027.6	1.4571 / 17 347.4
DIN W.Nr./ČSN	DN 80 - 150 1.4027 / 42 2906.5	1.4027 / 42 2906.5	1.4581 / 42 2941.4
Operating temperature range	-20 to 300°C	-20 to 500°C	-20 to 400°C
Face to face dimensions	Line 1 acc. to ČSN-EN 558-1 (3/1997)		
Flanges	Acc. to ČSN-EN 1092-1 (4/2002)		
Flange face	Type B1 (raised-faced) or Type F (female) acc. to ČSN-EN 1092-1 (4/2002)		
Type of plug	V-ported, parabolic, perforated		
Flow characteristic	Linear, equal-percentage, LDMspline®, parabolic		
Kvs value	1.6 to 360 m <sup>3</sup> /hour		
Leakage rate	Class III. acc. to ČSN-EN 1349 (5/2001) (<0.1% Kvs) for c. valves with metal-metal seat sealing Class IV. acc. to ČSN-EN 1349 (5/2001) (<0.01% Kvs) for c. valves with metal-PTFE seat sealing		
Rangeability r	50 : 1		
Packing	O - ring EPDM $t_{max}=140^{\circ}C$ , DRSpack® (PTFE) $t_{max}=260^{\circ}C$ , Exp. graphite, bellows $t_{max}=500^{\circ}C$		

Remark: For low operating temperatures (-200 to +250°C), it is possible to supply the valve RV 232 with body material made of 1.4308 (cast stainless steel).

## Kvs and differential pressure values with electromechanic actuators

$\Delta p_{max}$  value is the valve max. differential pressure when open-close function is always guaranteed. In regard of service life of seat and plug, it is recommended so that permanent

differential pressure would not exceed 1.6 MPa. Otherwise it is suitable to use perforated plug or sealing surfaces of seat and plug with a hard metal overlay.

		Actuating (actuator)			VA-7810-xxx-12	RA-3xxx-712x	FA-10xx-210x	RA-3xxx-722x	FA-22xx-751x FA-25xx-751x	RA-3xxx-732x	FA-33xx-741x		
		Mark in valve spec. No.			ECN	ECI	HCJ	ECI	ECK	ECI	ECL		
		Linear force			1000 N $\pm 20\%$			1000 N	700 N	1800 N	2300 N	3000 N	6000 N
		Kvs [m <sup>3</sup> /hour]			$\Delta p_{max}$	$\Delta p_{max}$	$\Delta p_{max}$	$\Delta p_{max}$	$\Delta p_{max}$	$\Delta p_{max}$	$\Delta p_{max}$		
DN	H	1	2	3	metal PTFE	metal PTFE	metal PTFE	metal PTFE	metal PTFE	metal PTFE	metal PTFE		
15	13	---	2.5 <sup>1)</sup>	1.6 <sup>1)</sup>	1.79 ---	4.00 ---	0.65 ---	---	---	---	---		
15		4.0 <sup>1)</sup>	---	---	0.75 ---	1.92 ---	0.16 ---	---	---	---	---		
20		---	---	2.5 <sup>1)</sup>	1.79 ---	4.00 ---	0.65 ---	---	---	---	---		
20		---	4.0 <sup>1)</sup>	---	0.75 ---	1.92 ---	0.16 ---	---	---	---	---		
20		6.3 <sup>1)</sup>	---	---	0.23 ---	0.82 ---	---	---	---	---	---		
25		10.0	6.3 <sup>2)</sup>	4.0 <sup>2)</sup>	0.05 0.46	0.42 0.83	---	0.28	---	---	---		
32		16.0	10.0	6.3 <sup>2)</sup>	---	0.27	0.17 0.49	---	0.16	---	---		
40		25.0	16.0	10.0	---	0.17	0.06 0.31	---	0.10	---	---		
50	25	40.0	25.0	16.0	---	---	---	---	0.33 0.52	0.54 0.74	---		
65		63.0	40.0	25.0	---	---	---	---	0.16 0.32	0.29 0.45	---		
80	42	100.0	63.0	40.0	---	---	---	---	---	---	0.19 0.32	0.73 0.86	
100		160.0	100.0	63.0	---	---	---	---	---	---	0.10 0.21	0.45 0.56	
125		250.0	160.0	100.0	---	---	---	---	---	---	0.05 0.13	0.27 0.36	
150		360.0	250.0	160.0	---	---	---	---	---	---	0.02 0.09	0.18 0.25	

## Kvs and differential pressure values with pneumatic actuators

$\Delta p_{max}$  value is the valve max. differential pressure when open-close function is always guaranteed. In regard of service life of seat and plug, it is recommended so that permanent

differential pressure would not exceed 1.6 MPa. Otherwise it is suitable to use perforated plug or sealing surfaces of seat and plug with a hard metal overlay.

		Pneumatic actuator			MP 8000		PA 2000					
		Spec. No. of actuator			MP822Exx20	MP832Exx20	PA-2xxx-3317	PA-2xxx-3327	PA-2xxx-3717	PA-2xxx-3727	PA-2xxx-3617	PA-2xxx-3627
		Actuator function			fail to open	fail to close	fail to open	fail to close	fail to open	fail to close	fail to open	fail to close
		Spring range [bar]			0,6 - 0,9	0,6 - 0,9	0,7 - 1,0	0,7 - 1,0	0,7 - 1,0	0,7 - 1,0	0,7 - 1,0	0,7 - 1,0
		Spring setting [bar]			0,6	0,6	0,7	0,7	0,7	0,7	0,7	0,7
		Feeding pressure [bar]			1,6	1,1	1,6	1,2	1,6	1,2	1,6	1,2
		Mark in valve spec. No.			PCA		PCB					
		Linear force			1120 N	960 N	1800 N	2100 N	3600 N	4200 N	3600 N	4200 N
		Kvs [m <sup>3</sup> /hour]			$\Delta p_{max}$	$\Delta p_{max}$	$\Delta p_{max}$	$\Delta p_{max}$	$\Delta p_{max}$	$\Delta p_{max}$	$\Delta p_{max}$	$\Delta p_{max}$
DN	H	1	2	3	metal PTFE	metal PTFE	metal PTFE	metal PTFE	metal PTFE	metal PTFE	metal PTFE	metal PTFE
15	13	---	2.5 <sup>1)</sup>	1.6 <sup>1)</sup>	4.00 ---	3.61 ---	---	---	---	---	---	---
15		4.0 <sup>1)</sup>	---	---	2.63 ---	1.69 ---	---	---	---	---	---	---
20		---	---	2.5 <sup>1)</sup>	4.00 ---	3.61 ---	---	---	---	---	---	---
20		---	4.0 <sup>1)</sup>	---	2.63 ---	1.69 ---	---	---	---	---	---	---
20		6.3 <sup>1)</sup>	---	---	1.17 ---	0.70 ---	---	---	---	---	---	---
25		10.0	6.3 <sup>2)</sup>	4.0 <sup>2)</sup>	0.63 1.05	0.34 0.75	---	---	---	---	---	---
32		16.0	10.0	6.3 <sup>2)</sup>	0.31 0.63	0.13 0.45	---	---	---	---	---	---
40		25.0	16.0	10.0	0.14 0.40	0.03 0.28	---	---	---	---	---	---
50	25	40.0	25.0	16.0	---	---	0.33 0.52	0.46 0.65	1.10 1.29	1.35 1.54	---	---
65		63.0	40.0	25.0	---	---	0.16 0.32	0.24 0.39	0.63 0.78	0.79 0.94	---	---
80	42	100.0	63.0	40.0	---	---	---	---	---	---	0.30 0.43	0.41 0.54
100		160.0	100.0	63.0	---	---	---	---	---	---	0.17 0.28	0.24 0.35
125		250.0	160.0	100.0	---	---	---	---	---	---	0.09 0.18	0.14 0.22
150		360.0	250.0	160.0	---	---	---	---	---	---	0.05 0.12	0.08 0.16

- 1) parabolic plug in straight way, V-ported plug in angle way
- 2) V-ported plug in angle way, in straight way for linear characteristic V-ported plug and for equal-percentage characteristic parabolic plug.

Bellows packing can be used with V-ported plug only.

Max. differential pressure  $\Delta p$  for valves PN 16 must be 1.6 MPa.

metal - version with metal - metal seat sealing

PTFE - version with metal - PTFE seat sealing

Max. differential pressures specified in table apply to PTFE and O-ring packing.  $\Delta p_{max}$  for bellows must be consulted with the producer.

It applies to graphite packing as well especially when required  $\Delta p$  value is close to max. values specified in table.

## Dimensions and weight for the type RV 2x4

DN	PN 16					PN 40					PN 16, PN 40													
	D <sub>1</sub> mm	D <sub>2</sub> mm	D <sub>3</sub> mm	d mm	n	D <sub>1</sub> mm	D <sub>2</sub> mm	D <sub>3</sub> mm	d mm	n	D mm	f mm	D <sub>4</sub> mm	D <sub>5</sub> mm	L mm	V <sub>1</sub> mm	V <sub>2</sub> mm	#V <sub>2</sub> mm	V <sub>3</sub> mm	#V <sub>3</sub> mm	a mm	m <sub>1</sub> kg	m <sub>2</sub> kg	#m <sub>v</sub> kg
15	95	65	45	14	4	95	65	45	14	4	15	2	54	12	130	110	98	---	156	---	16	5.5	6	---
20	105	75	58			105	75	58			20				150	115	98	---	156	---	18	6.5	7	---
25	115	85	68			115	85	68			25				160	130	103	238	161	296	18	8.3	9.5	3.5
32	140	100	78			140	100	78			32				180	135	103	238	161	296	20	10.5	12	3.5
40	150	110	88	18	8	150	110	88	18	8	40	2	54	12	200	140	103	238	161	296	20	12	13.5	3.5
50	165	125	102			165	125	102			50				230	175	110	298	176	364	20	17	24	4
65	185	145	122			185	145	122			65				290	180	110	298	176	364	22	22	31	4
80	200	160	138			200	160	138			80				310	220	123	440	189	506	24	31	43	4.5
100	220	180	158	22	8	235	190	162	22	8	100	2	54	13.8	350	230	123	440	189	506	24	44	55	4.5
125	250	210	188			270	220	188			125				400	260	151	468	217	534	26	65	90	5
150	285	240	212			300	250	218			150				480	290	151	468	217	534	28	94	120	5

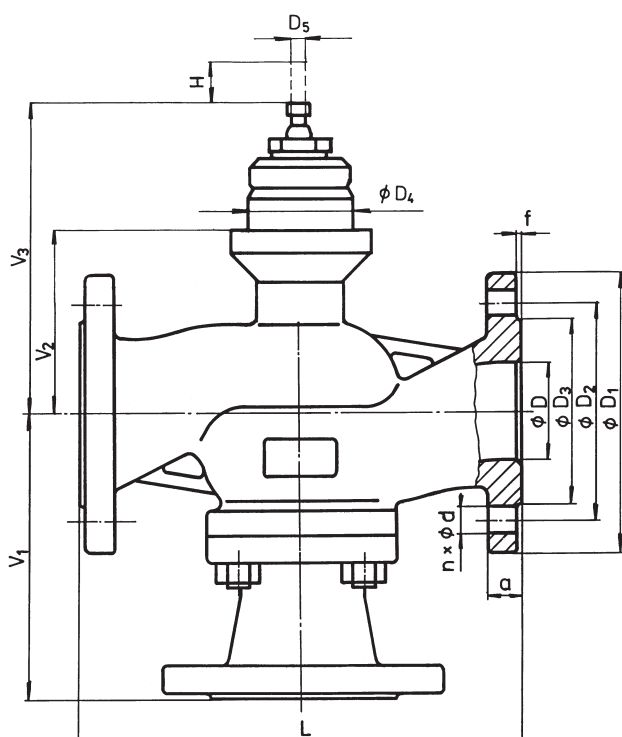

<sup>1)</sup> with regard of the standard previously in force, there is an option to have the number of connection bolts as stipulated in ČSN-EN 1092-1

<sup>#)</sup> - for valve with bellows packing

m<sub>v</sub> - weight to be added to weight of valve equipped with bellows packing

m<sub>1</sub> - for valves RV 214

m<sub>2</sub> - for valves RV 224 and RV 234

## Valve complete specification No. for ordering RV 2x0, RV / HU 2x1, RV 2x2, RV 2x4

		XX	XXX	XXX	XXXX	XX	-XX	/XXX	-XXX
1. Valve	Control valve	RV							
	Fail-safe action valve	HU							
2. Series	Valves made of spheroidal cast iron		2 1						
	Valves made of cast steel		2 2						
	Valves made of stainless steel		2 3						
	Direct valve		0						
	Reverse valve		1						
	Pressure-balanced, direct valve		2						
	Mixing (diverting) valve		4						
3. Actuating <sup>1)</sup> $t_{max} = 140^{\circ}C$ <sup>5)</sup> Fail-safe action actuators	Electric actuator			E					
	Pneumatic actuator			P					
	Electrohydraulic actuator			H					
	Electric actuator VA-7810-xxx-12 <sup>1)</sup>			E C N					
	Electric actuator RA-3xxx-7xxx			E C I					
	Electrohydraulic actuator FA-10xx-210x <sup>5)</sup>			H C J					
	Electric actuator FA-2xxx-7x1x			E C K					
	Electric actuator FA-33xx-741x			E C L					
	Pneumatic actuator MP 8000			P C A					
	Pneumatic actuator PA 2000			P C B					
4. Connection	Raised flange				1				
	Female flange				2				
5. Body material  <i>(operating temperature ranges are specified in parentheses)</i>	Cast steel 1.0619 (-20 to 400°C)				1				
	Sphr. cast iron EN-JS 1025 (-20 to 300°C)				4				
	CrMo steel 1.7357 (-20 to 500°C)				7				
	Stained steel 1.4581 (-20 to 400°C)				8				
	Other material on request				9				
6. Seat sealing <sup>2)</sup> od DN 25; $t_{max} = 260^{\circ}C$	Metal - metal				1				
	Soft sealing (metal - PTFE) in straight way <sup>2)</sup>				2				
	Hard metal overlay on sealing surfaces				3				
7. Packing <sup>3)</sup> Not applicable to RV 2x2	O - ring EPDM				1				
	DRSpack® (PTFE)				3				
	Graphite <sup>3)</sup>				5				
	Bellows				7				
	Bellows with safety PTFE packing				8				
	Bellows with Graphite packing <sup>3)</sup>				9				
8. Flow characteristic <sup>4)</sup> Not applicable to RV 2x4	Linear					L			
	Equal-percentage					R			
	LDMspline® <sup>4)</sup>					S			
	Parabolic <sup>4)</sup>					P			
	Linear - perforated plug <sup>4)</sup>					D			
	Equal-percentage - perforated plug <sup>4)</sup>					Q			
	Parabolic - perforated plug <sup>4)</sup>					Z			
9. Kvs	Column No. acc. to Kvs values table					X			
10. Nominal pressure PN	PN 16						16		
	PN 40						40		
11. Max. operating temp. °C	O - ring EPDM							140	
	DRSpack® (PTFE), bellows							220	
	DRSpack® (PTFE), bellows							260	
	Graphite; bellows <sup>3)</sup>							300	
	Graphite; bellows <sup>3)</sup>							400	
	Graphite; bellows <sup>3)</sup>							550	
12. Nominal size DN	DN								XXX

**Ordering example :** Two-way control valve DN 65, PN 40, with electric actuator RA-3105-7227, body material: spheroidal cast iron, flange<sub>3</sub> with raised face, metal-PTFE seat sealing, packing PTFE, linear flow characteristic, Kvs = 63 m<sup>3</sup>/hour is specified as follows : **RV 210 ECI 1423 L1 40/220-65**

### Valves RV 2x0

Section of valve with V-ported plug

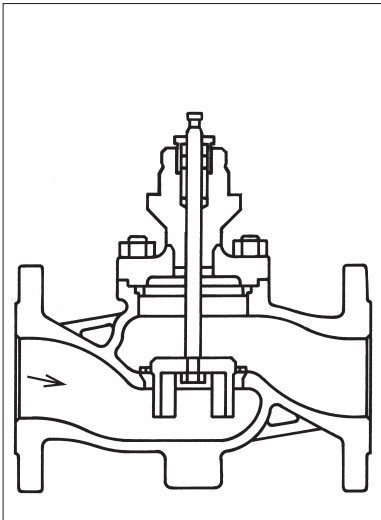

Section of valve with perforated plug

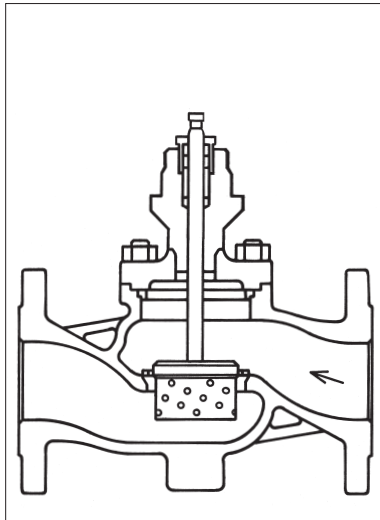

### Valves RV / HU 2x1

Section of valve with V-ported plug

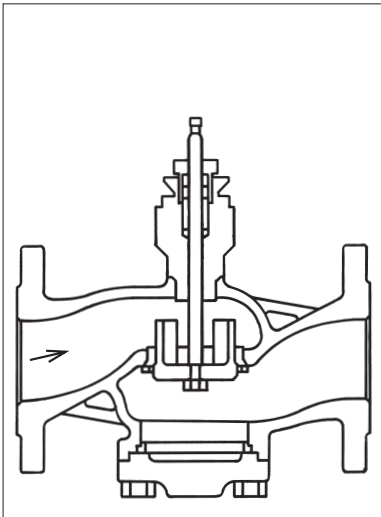

Section of valve with perforated plug

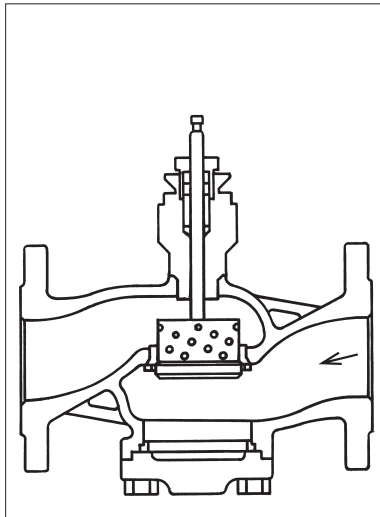

### Valves RV 2x2

Section of pressure-balanced valve with V-ported plug

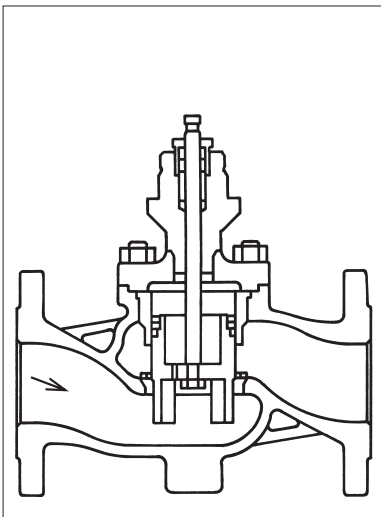

Section of pressure-balanced valve with perforated plug

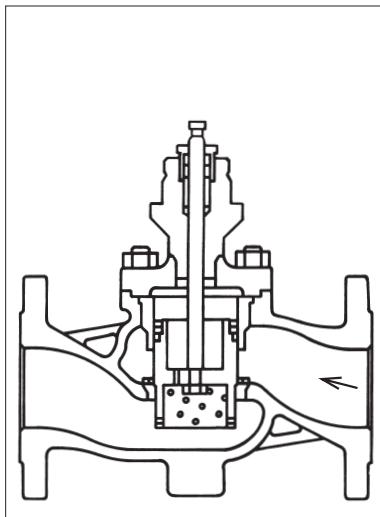

### Valves RV 2x4

Section of three-way valve with V-ported plug

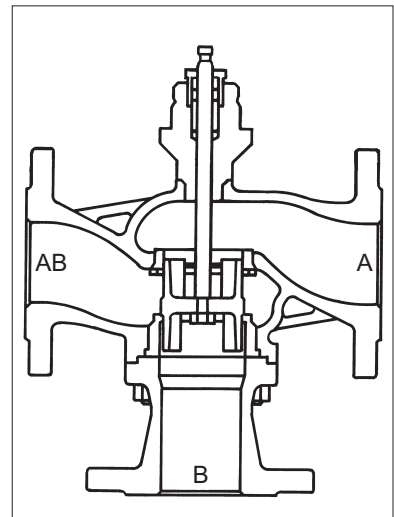



## Electric actuator VA-77xx-100x Johnson Controls

### Technical data

Type	VA-77xx-100x
Marking in valve specification No.	ECM
Voltage	24 V AC, 230 V AC
Frequency	50 / 60 Hz
Power consumption	2,4 VA
Control	3 - position, 0 - 10 V, 0 (4) - 20mA
Open-close running time	6 mm/min (for 50 Hz)
Nominal force	500 N $\pm$ 20%
Travel	max. 20 mm
Enclosure	IP 54
Process medium max. temperature	140°C
Ambient temperature range	-5 to 55°C
Ambient humidity limit	10 - 90% of relative humidity, without condensation
Weight	0,8 kg

### Dimension of actuator

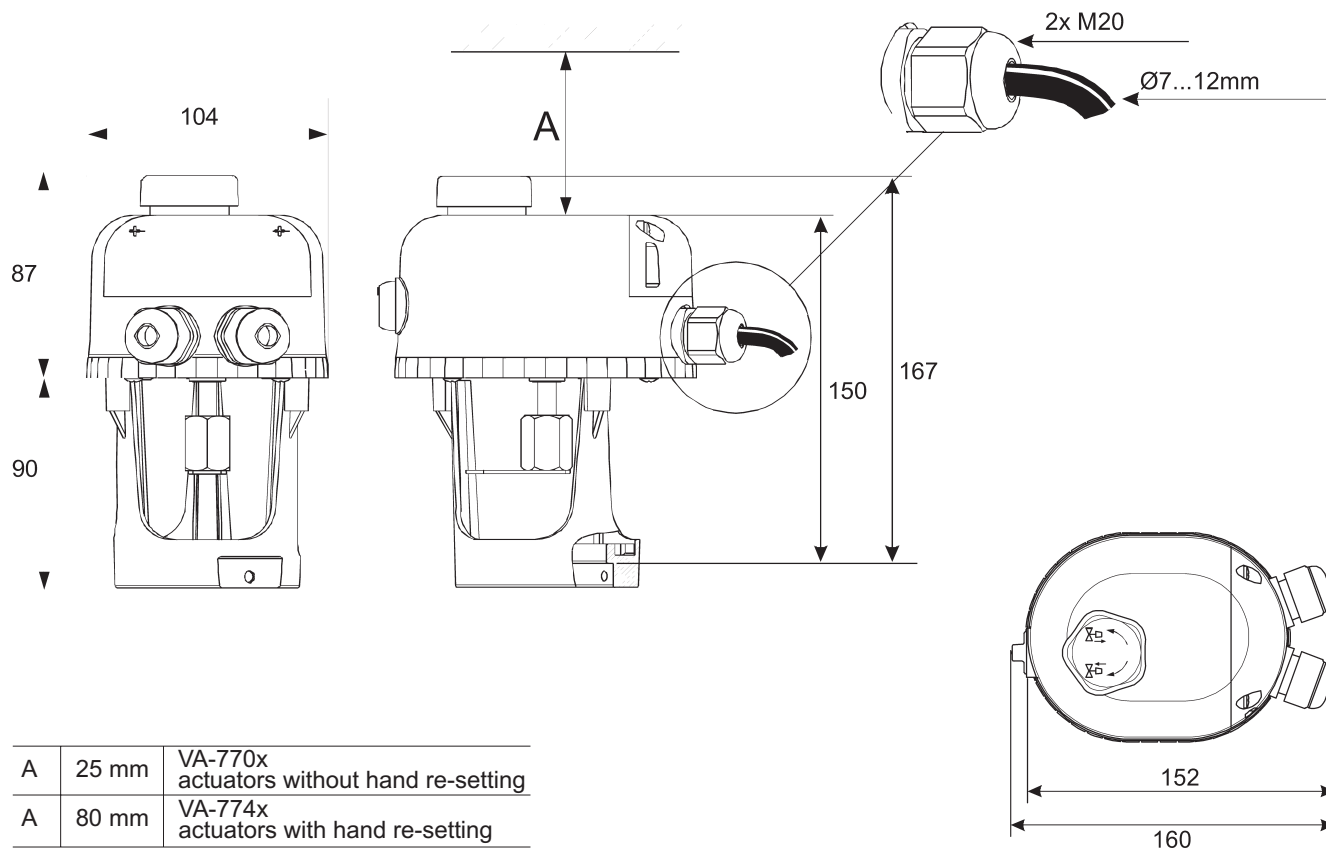

## Specification of actuators VA-715x-100x

		VA - 77	X	X	-	1	0	0	X
Hand wheel	Reversible, without feedback		0						
	Proportional control with signal 0 - 10 V		4						
Control	3 - position			0					
	Proportional 0-10 V / 0 (4) - 20 mA			6					
Voltage	24 V								1
	230 V (just 3-position models)								3

### Wiring diagrams of actuators

(Models with mechanical hand re-setting)

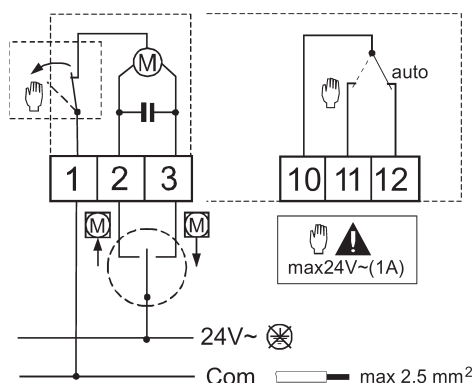

**VA-7740-1001**  
3-positions models, voltage 24 V

(Models without mechanical hand re-setting)

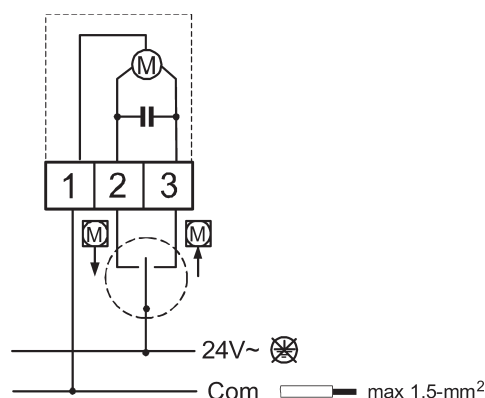

**VA-7700-1001**  
3-positions models, voltage 24 V

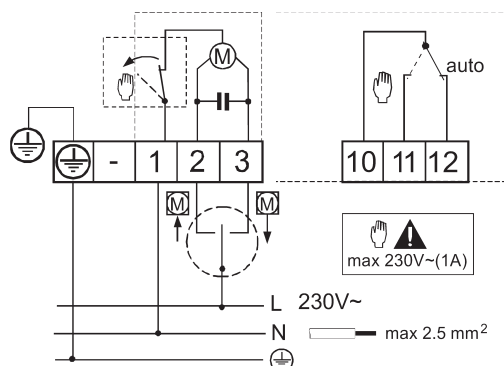

**VA-7740-1003**  
3-positions models, voltage 230 V

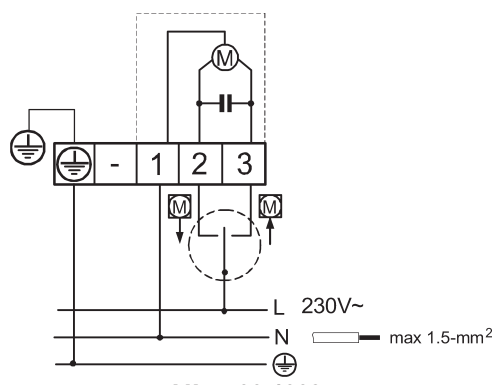

**VA-7700-1003**  
3-positions models, voltage 230 V

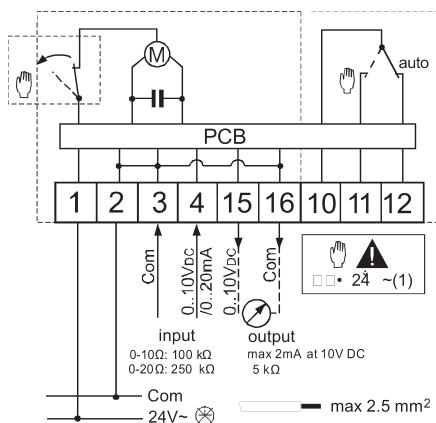

**VA-7746-1001**  
Proportional models, voltage 24 V

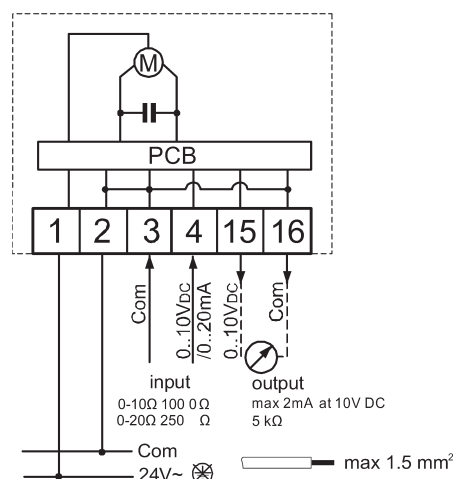

**VA-7706-1001**  
Proportional models, voltage 24 V



## Electric actuators VA-7810-xxx-1x of Johnson Controls

### Technical data

Type	VA-7810-xxx-1x
Mark in valve specification No.	ECN
Voltage	24 V AC or 230 V AC
Frequency	50 / 60 Hz
Motor power	max. 8 VA
Control	3-position or 0 (2) - 10 V, 0 (4) - 20 mA
Open-close running time	10 mm / min.
Nominal force	1000 N $\pm$ 20 %
Stroke	max. 25 mm
Enclosure	IP 54
Process medium max. temperature	140°C
Ambient temperature range	-5 to 55°C
Ambient humidity limit	10 - 90 % of relative humidity, without condensation
Weight	1,7 kg

### Dimensions of actuator

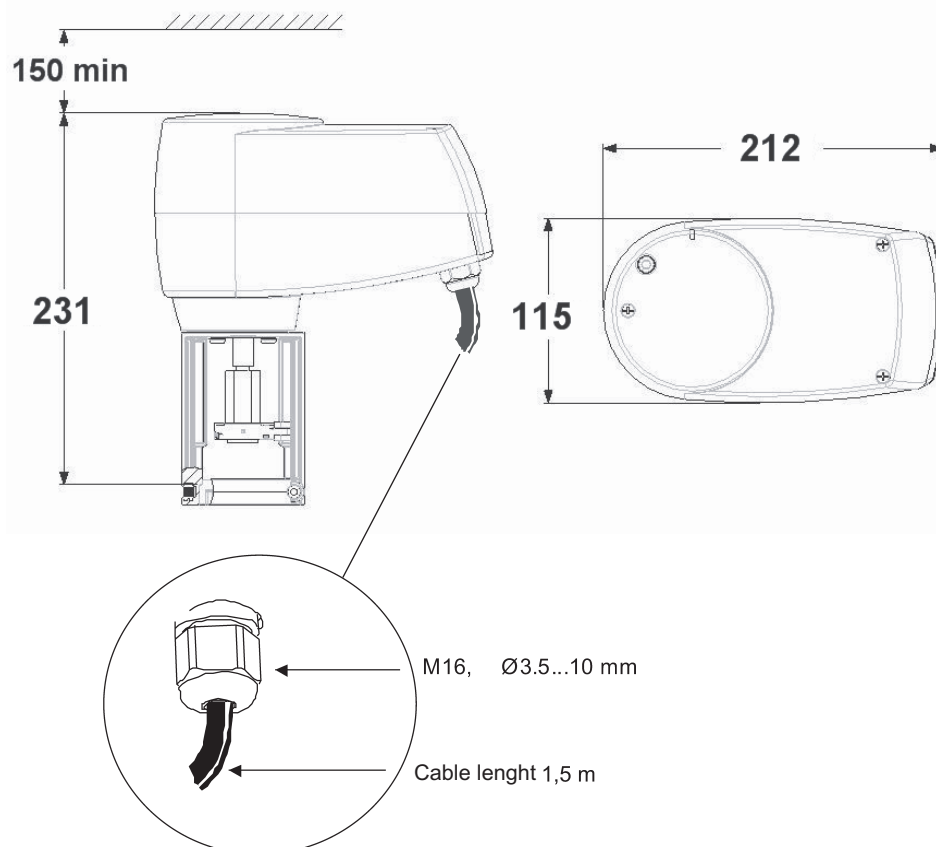



## Specification of actuators VA-715x-100x

		VA - 7 8 10	-XXX	-XX
3-position models	230 V AC		ADA	
	24 V AC		AGA	
	24 V AC, 2 additional switches		AGC	
	24 V AC, feedback potentiometer 2 kΩ		AGH	
Proportional models	24 V AC, 0 (2) - 10 V nebo 0 (4) - 20 mA		GGA	
	24 V AC, 0 (2) - 10 V nebo 0 (4) - 20 mA, 2 additional switches		GGC	
Connection for the actuator type	Thread coupling (RV 102, RV 103)			1 1
	Clamp coupling (200 line)			1 2

## Wiring diagrams of actuators

The actuators are delivered with the cable gland (length 1,5 m).  
The cable number name according to clamps marking of the actuator.

### 3-position models

VA7810-ADA-1x 230 V ~ 

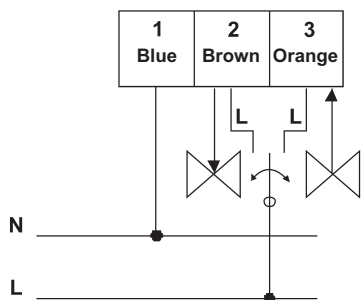

VA7810-AGA-1x 24 V ~ 

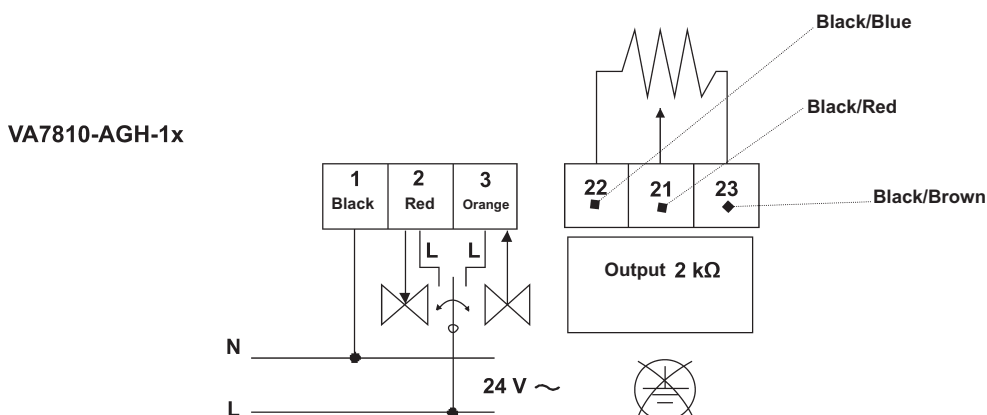
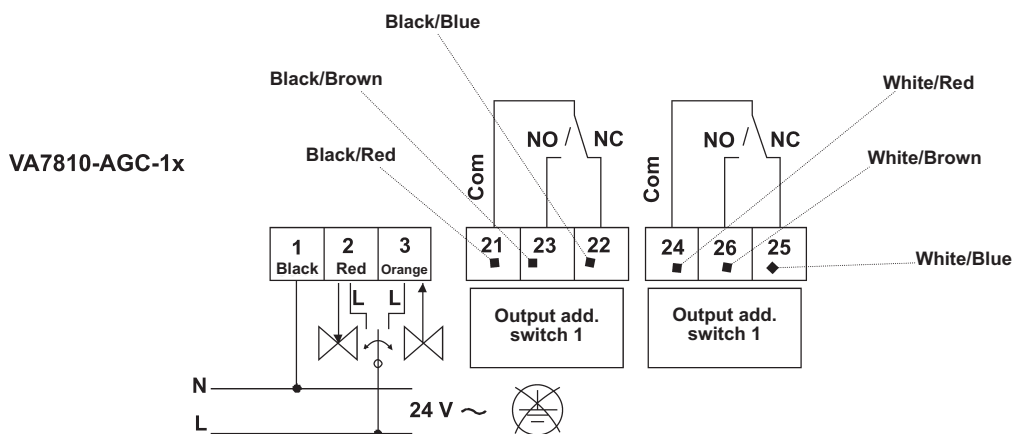
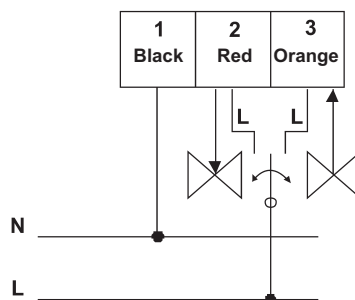

The actuators are delivered with the cable gland (length 1,5 m).  
The cable number name according to clamps marking of the actuator.

### Proportional models

#### VA7810-GGC-1x

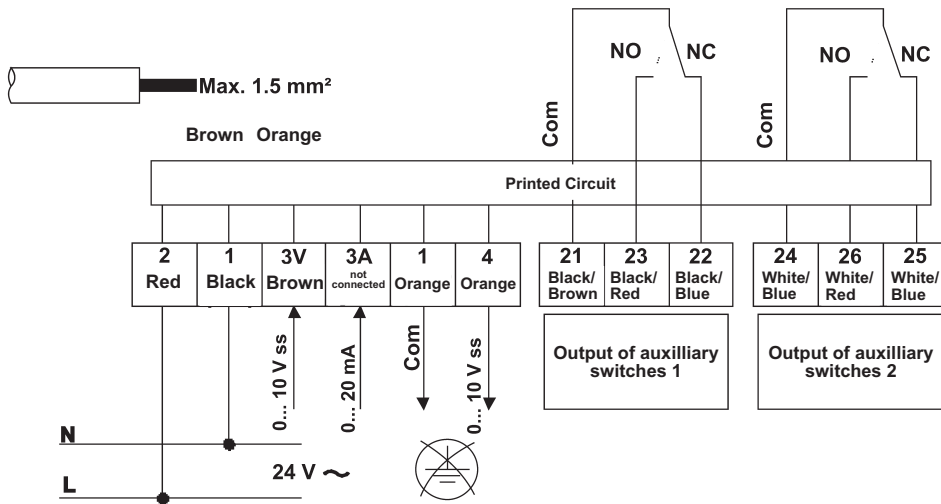

#### VA7810-GGA-1x

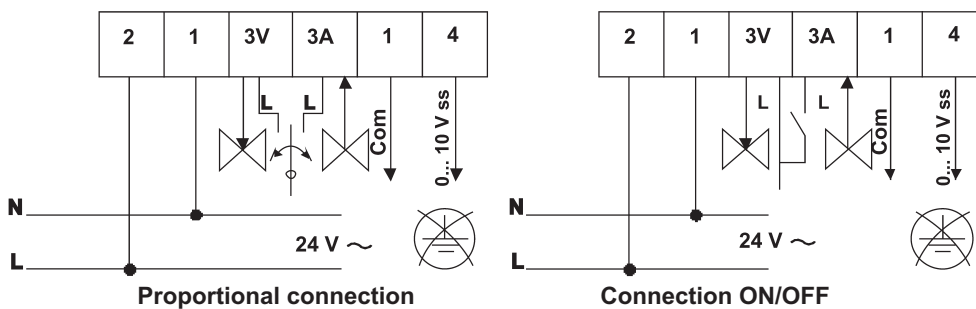
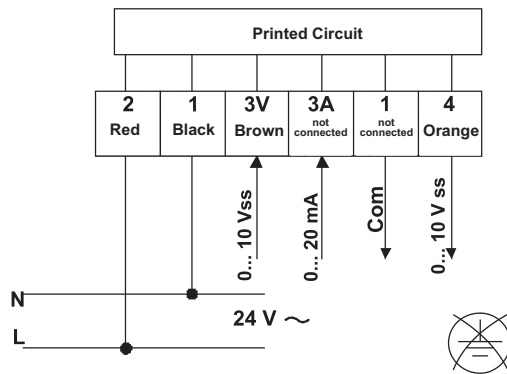



## Electric actuators RA-3xxx-7xxx of Johnson Controls

### Technical data

Type	RA-3xxx-712x	RA-3xxx-722x	RA-3xxx-732x
Mark in valve specification No.	ECI		
Voltage	24V or 230 V		
Frequency	50 / 60 Hz		
Motor power	7 VA, with positioner 9 VA	10 VA, with positioner 12 VA	16 VA, with positioner 18 VA
Control	3 - position or with signal of 0 - 10 V		
Open-close run time at 50(60)Hz	9,6 (11,5) mm/min	14,4 (17,2) mm/min	13,6 (16,3) mm/min
Nominal force	1000 N	1800 N	3000 N
Stroke	13 mm	25 mm	42 mm
Enclosure	IP 54		
Max. operating temperature	Acc. to used valve		
Ambient temperature range	-10 to 60°C (control 0 - 10 V -10 to 50°C)		
Ambient humidity limit	90 % without condensation		
Weight	4,2 kg	4,2 kg	4,4 kg

### Dimensions of actuator

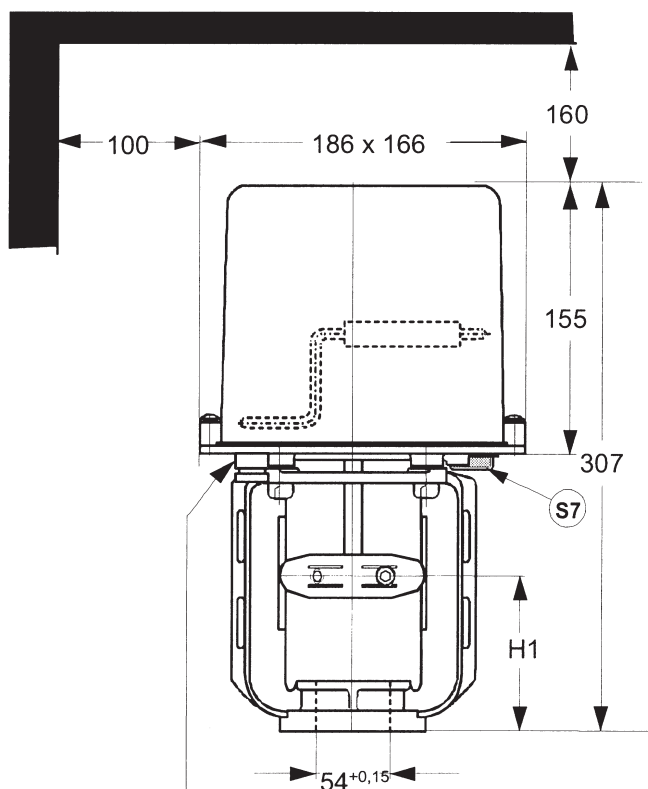

	H1
RA-3xxx-712x	58 mm
RA-3xxx-722x	66 mm
RA-3xxx-732x	66 mm

1x PG13,5 (for conduct. Ø7...11 mm)

+1 Blind socket

## Specification of actuators series RA-3xxx-7xxx

		RA-3	X	X	X	-7	X	X	X
Hand wheel	none	0							
	with hand wheel	1							
Accessories <small>(factory mounted)</small>	none		0	0					
	2 auxiliary switches and feedback potentiometer 2 kΩ		0	3					
	2 auxiliary switches and feedback potentiometer 135 kΩ		0	5					
	Built-in electronic positioner 0-10 VDC and two additional switches (for 24 V models only)		4	1					
Actuator's force and voltage	1000 N 24 VAC, 50/60 Hz								1 2 6
	1000 N 230 VAC, 50/60 Hz								1 2 7
	1800 N 24 VAC, 50/60 Hz								2 2 6
	1800 N 230 VAC, 50/60 Hz								2 2 7
	3000 N 24 VAC, 60 Hz								3 2 5
	3000 N 24 VAC, 50 Hz								3 2 6
	3000 N 230 VAC, 50 Hz								3 2 7

## Accessories

EQ-5687-7011	2 auxiliary switches and feedback potentiometer 2 kΩ
252 3501 114	lead-in insulator PG 13,5 (∅ 7..11 mm) DIN 46320 - FS

## Wiring diagrams

Models with floating (3-position) control (PAT)

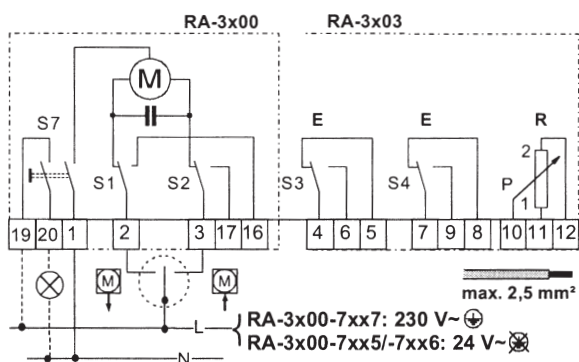

Models with proportional (0-10V) control

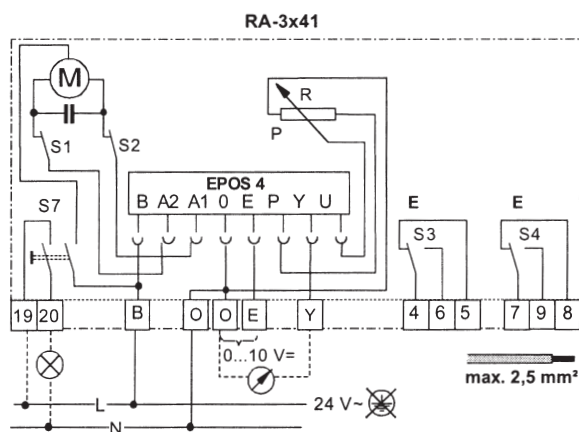

Actuators (24 V models only) with built-in positioner for regulators with output of 0 -10 V

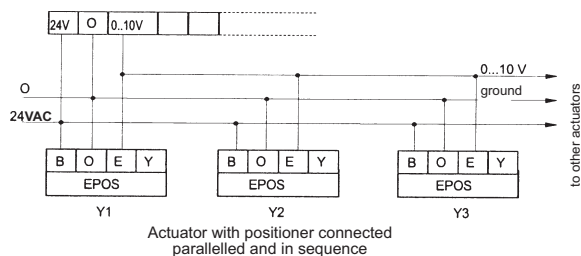



## Elektrohydraulic actuators FA-10xx-210x of Johnson Controls

### Technical data

Typ	FA-10xx-210x
Marking in valve specification No.	ECJ
Voltage	24 V or 230 V
Frequency	50 / 60 Hz
Power consumption	20 VA, with direct control 23 VA
Control	3 - position control or with signal 0 ... 10 V / 0 ... 20 mA
Open-close running time	6,5 mm/min
Fail-safe action time	20 ± 10 s
Nominal force	700 N
Travel	13 mm
Enclosure	IP 54
Process medium max. temper.	Acc. to used valve
Ambient temperature range	-5 to 50°C
Ambient humidity limit	95 % without condensation
Weight	3,5 kg

### Dimension of actuator

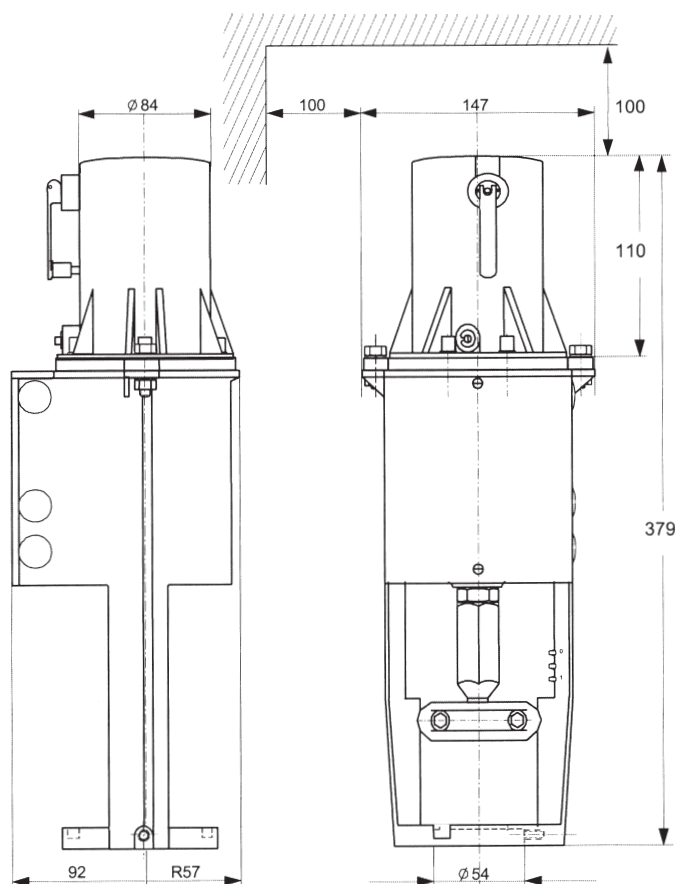

## Specification actuators series FA-10xx-210x

		FA-10	X X	- 210	X
Accessories <i>(factory mounted)</i>	none		0 0		
	2 auxiliary switches and feedback potentiometer 2 kΩ		0 3		
	2 auxiliary switches and feedback potentiometer 130 kΩ		0 5		
	Built-in electronic positioner 0 ... 10 V / 0 ... 20 mA (for 24 V models only)		4 0		
Voltage	230 VAC, 50/60 Hz				1
	24 VAC, 50/60 Hz				6

## Accessories

111 6133 010	2 signalisation switches (not available for models with 0 ... 10 V control)
111 6134 010	feedback potentiometer 2 kΩ (not available for models with 0 ... 10 V control)
111 6135 010	feedback potentiometer 130 kΩ (not available for models with 0 ... 10 V control)
282 3501 113	PG 11 x 7 ... 9 mm bolt
111 6142 010	* 24V hydraulic unit (spare part)
111 6142 020	* 230V hydraulic unit (spare part)

\* hydraulic pump and motor

## Wiring diagrams

Models with floating (3-position) control (PAT)

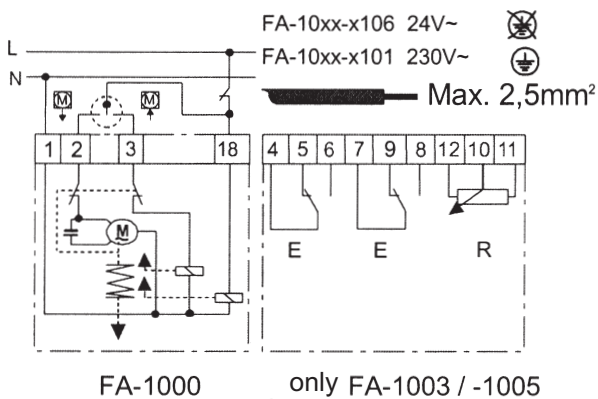

Models with proportional (0-10V) control

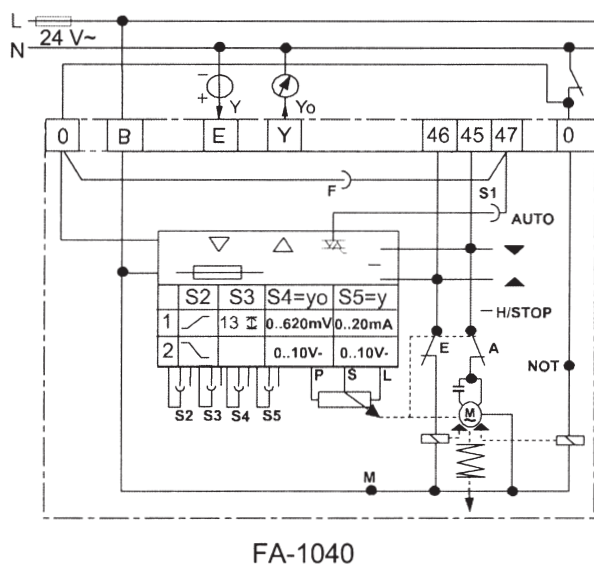



## Electric actuator FA-2xxx-7x1x Johnson Controls

### Technical data

Typ	FA-22xx-751x	FA-25xx-751x	FA-23xx-741x	FA-26xx-741x
Marking in valve specification No.	ECK			
Voltage	24 V or 230 V			
Frequency	50 Hz			
Power consumption	24 V = 6,1 VA: 230 V = 5 VA			
Control	3 - position control or with signal 0 ... 10 V / 0 ... 20 mA			
Open-close running time	17,5 mm/min			
Nominal force	2400 N		2200 N	
Travel	25 mm		42 mm	
Enclosure	IP 54			
Process medium max. temper.	Acc. to used valve			
Ambient temperature range	-20 to 60°C			
Ambient humidity limit	90 % without condensation			
Weight	9,4 kg		9,8 kg	

### Dimension of actuator

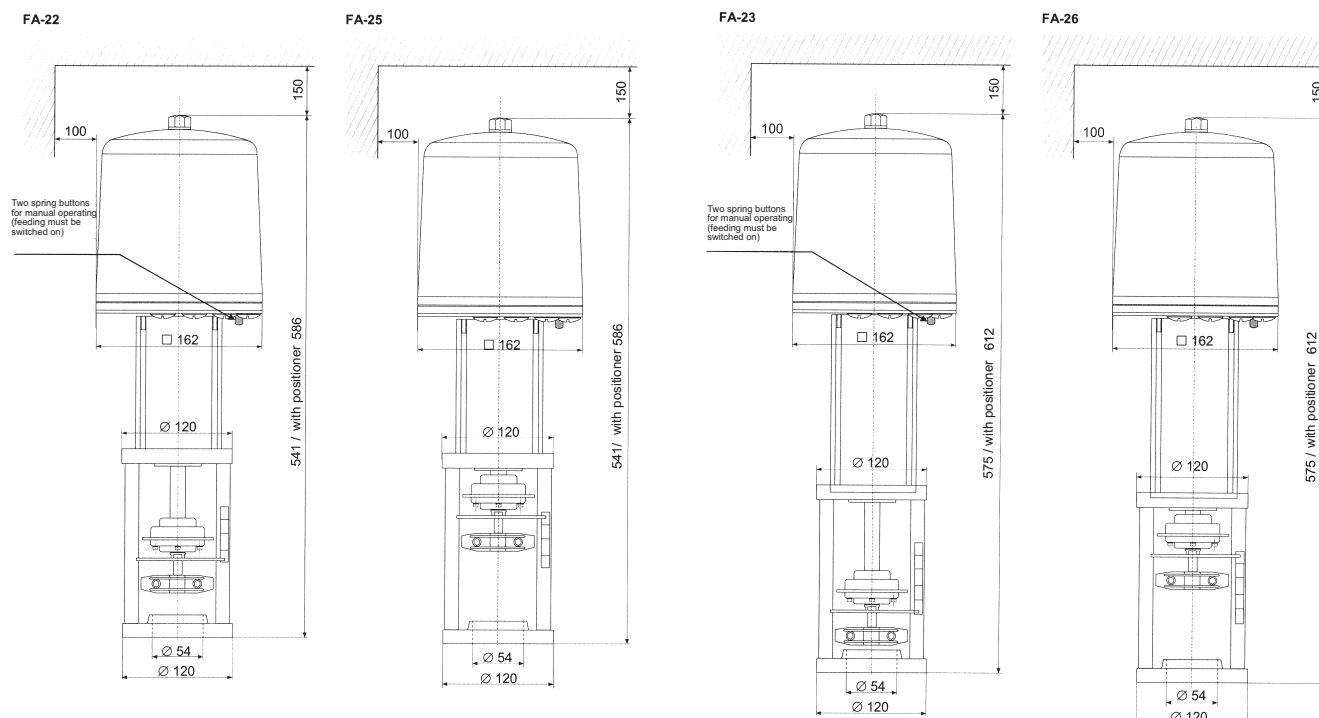

## Specification of actuators series FA-2xxx-7x1x

		FA-2	X	X	X	-	7X1	X
Return spring	Safety position :stem fully extended		2					751
	Safety position :stem fully retracted		5					
	Safety position :stem fully extended		3					741
	Safety position :stem fully retracted		6					
Accessories <small>(factory mounted)</small>	none						0 0	
	2 auxiliary switches						0 1	
	Feedback potentiometer 2 k $\Omega$						0 2	
	2 auxiliary switches and feedback potentiometer 2 k $\Omega$						0 3	
	Feedback potentiometer 135 k $\Omega$						0 4	
	Built-in electronic positioner 0 ... 10 V / 0 ... 20 mA (for 24 V models only)						4 0	
	2 auxiliary switches, built-in electronic positioner 0 ... 10 V / 0 ... 20 mA						4 1	
Voltage	230 V, 50 Hz							1
	24 V, 50 Hz							6

## Accessories

EQ-1008-7101		2 signalisation switches
EQ-1007-7101		spare printed circuit for actuator
EQ-1009-7101	for FA-22 and FA-25	Position indicator, feedback 2 k $\Omega$ (not available for models with control 0 ... 10 V)
EQ-1029-7101		Position indicator, feedback 135 k $\Omega$ (not available for models with control 0 ... 10 V)
EQ-1010-7101		* Potentiometer 2 k $\Omega$ (not available for models with control 0 ... 10 V)
EQ-1030-7101		* Potentiometer 135 k $\Omega$ (not available for models with control 0 ... 10 V)
EQ-1016-7101	for FA-23 and FA-26	Position indicator, feedback 2 k $\Omega$ (not available for models with control 0 ... 10 V)
EQ-1017-7101		Position indicator, feedback 135 k $\Omega$ vysílač (not available for models with control 0 ... 10 V)
EQ-1018-7101		* Potentiometer 2 k $\Omega$ (not available for models with control 0 ... 10 V)
EQ-1019-7101		* Potentiometer 135 k $\Omega$ (not available for models with control 0 ... 10 V)

\* models with position indicator have potentiometer installed as standard

## Wiring diagrams

Models with floating (3-position) control (PAT)

FA-2x0x-7x1x

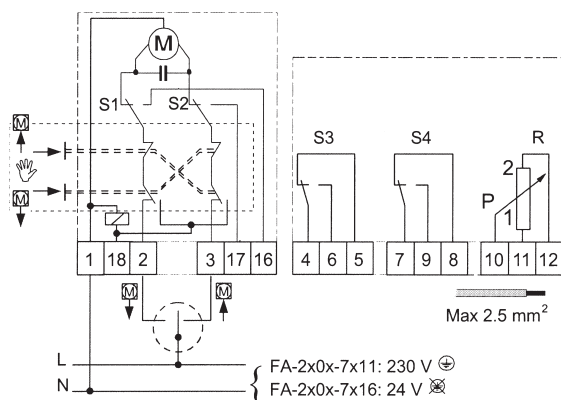

Models with proportional (0-10V) control

FA-2x4x-7x1x

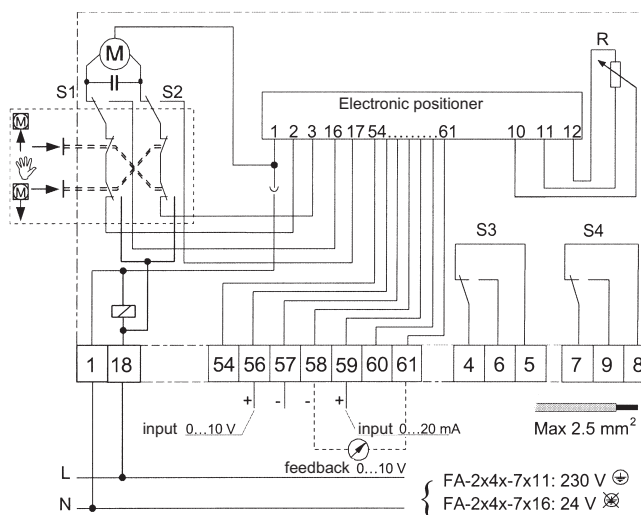





## Electric actuator FA-33xx-741x Johnson Controls

### Technical data

Type	FA-33xx-741x
Marking in valve specification number	ECL
Feeding pressure	24 V or 230 V
Frequency	50 Hz
Power consumption	37 VA (42 VA with positioner)
Control	3 - position control or with signal 0 - 10 V
Open-close running time	17 mm/min
Nominal force	6000 N + 300 N
Travel	42 mm; max. 45 mm
Enclosure	IP 65
Process medium max. temperature	Acc. to used valve
Ambient temperature range	-20 to 60°C
Ambient humidity range	90 % without condensation
Weight	7,5 kg

### Dimension of actuator

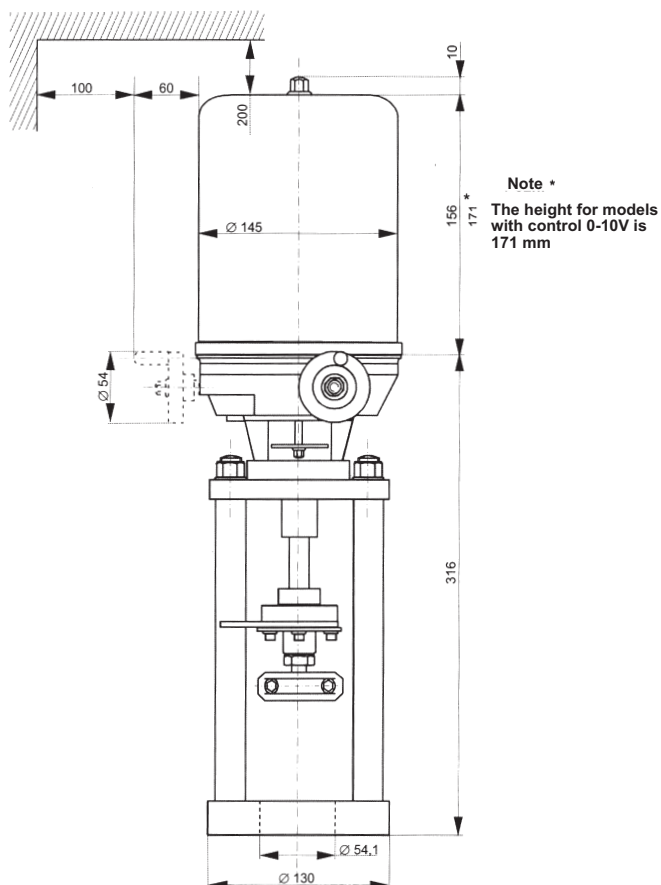

## Specification of actuators series FA-33xx-741x

		FA-33	X X	-	741	X
Accessories <i>(factory mounted)</i>	none		0 0			
	2 auxiliary switches and feedback potentiometer 2 kΩ		0 3			
	Feedback potentiometer 135 kΩ		0 4			
	Built-in electronic positioner 0 ... 10 V / 0 ... 20 mA and 2 auxiliary switches		4 1			
Voltage	230 VAC, 50 Hz					1
	24 VAC, 50 Hz					6

## Accessories

EQ-1003-7101	2 auxiliary switches and feedback potentiometer 2 kΩ
EQ-1013-7101	Feedback potentiometer 135 kΩ
EQ-1015-7101	Electronic positioner 0 ... 10 V or 0 ... 20 mA, telescopic modul for change at place (spare part)

## Wiring diagram

Floating (3-position) control (PAT)

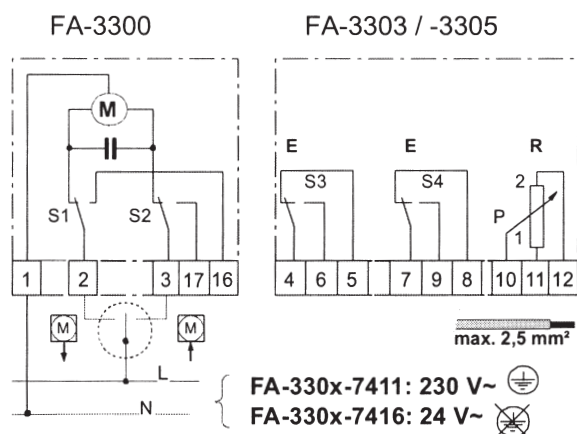

Proportional (0-10V) control

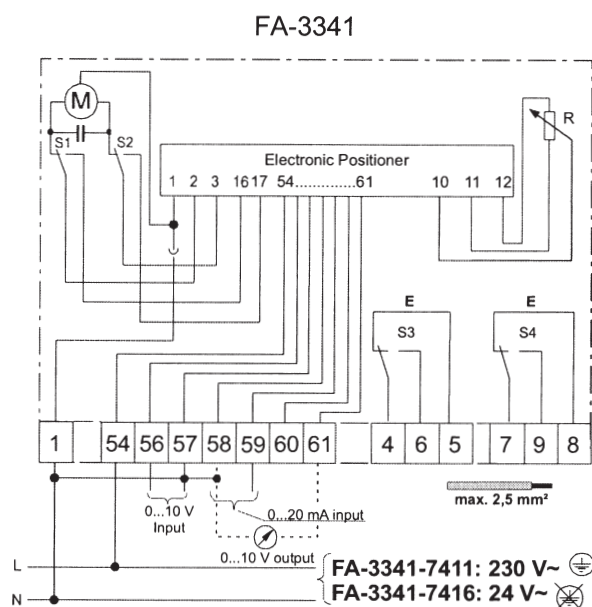

Actuators with built-in positioner for regulator with feedback 0-10 V

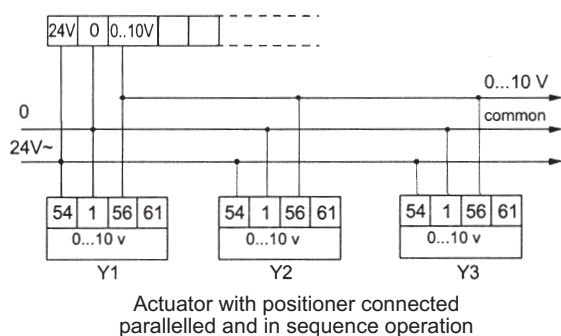



## Pneumatic actuators MP-8000 Johnson Controls

### Technical data

Type	MP 8x 2xxx20
Marking in valve specification number	PCA
Feeding pressure	max. 1,6 bar
Function	direct or indirect
Control	ON - OFF
	Pneumatic signal 20 - 100 kPa (with positioner PY-1010)
Nominal force	960 - 1760 N (acc. type)
Travel	13 mm
Process medium max. temperature	Acc. to used valve
Ambient temperature range	-4 to 80°C
Ambient humidity range	5 - 100 %
Weight	5 kg (6kg with positioner)

### Accessories

Pneumatic positioner (corrector) (type PY-1010)	serves for adjusting of required stroke value with the aid of pneumatic signal 20 to 100kPa
Signalisation switches	adjustable end position switches
Position transmitter	resistance output signal (0 - 2 kΩ)
Manual operating	for fail to open (NO) or fail to close function (NC) of actuator

### Operating conditions

Pneumatic actuators can be installed in open atmosphere. They can operate in explosive environment acc. to class SNV1 to SNV3. If there is any additional electric equipment used in actuator, then its application in environment SNV is limited by this additional equipment.

### Direct and indirect functions

Direct function ensures that actuator stem (draw bar) retracts upon air supply failure (valve opens).

Indirect function ensures that actuator stem (draw bar) extends upon air supply failure (valve closes).

## Specification of actuators series MP-8000

		MP8	X	2	X	X	X	20
Function, size	D.A., diaphragm 160 cm <sup>2</sup> (air to close, fail to open)		2					
	R.A., diaphragm 160 cm <sup>2</sup> (air to open, fail to close)		3					
Spring range	20 ... 50 kPa				C			
	60 ... 90 kPa				E			
Accessories <small>feedback and switches</small>	none							5
	positioner D.A., PY-1010							6
	positioner D.A., PY-1010 with hand wheel							7
	hand wheel							8
Accessories <small>positioner and hand wheel</small>	none							0
	feedback 2 k $\Omega$							1
	feedback 2 k $\Omega$ and 2 auxiliary switches							2
	2 auxiliary switches							3

## Dimensions of actuator series MP-8000

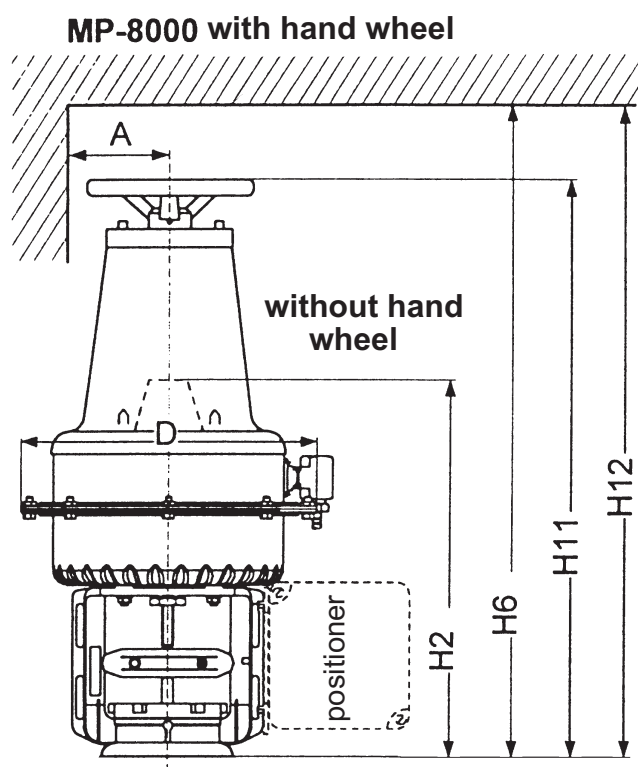

DN	A	D	H2	H6	H11	H12
15 - 40	160	220	264	414	394	544



**PCB**

## Pneumatic actuators PA-2000 Johnson Controls

### Technical data

Type	PA-2xxx-3xxx
Marking in valve specification No.	PCB
Feeding pressure	max. 1,6 bar
Function	direct or indirect
Control	ON - OFF
	Pneumatic signal 20 - 100 kPa (with positioner PY-1010)
Nominal force	1800 - 6600 N (acc. type)
Travel	25, 42 mm
Process medium max. temperature	Acc. to used valve
Ambient temperature range	-30 to 80°C
Ambient humidity range	5 - 100 %
Weight	actuator with diaphragm 300 cm <sup>2</sup> - 6 kg (7kg with positioner) pohon s membránou 600 cm <sup>2</sup> - 17 kg (18kg with positioner)

### Accessories

Pneumatic positioner (corector) (type PY-1010)	serves for adjusting of required stroke value with the aid of pneumatic signal 20 to 100kPa
Signalisation switches	adjustable end position switches
Position transmitter	resistance output signal (0 - 2000 Ω)
Manual operating	for fail to open (NO) or fail to close function (NC) of actuator

### Service conditions

Pneumatic actuators can be installed in open spaces. The can operate in explosive environment.

### Direct and indirect functions

Direct function ensures that actuator stem (draw bar) retracts upon air supply failure (valve opens).  
Indirect function ensures that actuator stem (draw bar) extends upon air supply failure (valve closes).

## Specification of actuators series PA-2000

		PA-2	X	X	X	-3	X	X	X
Manual operating	none	0							
	with hand wheel	1							
Positioner <small>factory mounted</small>	none	0							
	DA type (PY-1010)	3							
Accessories <small>feedback and switches</small>	none					0			
	2 auxiliary switches					1			
	Feedback 2 k $\Omega$					2			
	Feedback 2 k $\Omega$ and 2 auxiliary switches					3			
Size	300 cm <sup>2</sup> , standard for DN0 50 and 65							3	
	600 cm <sup>2</sup> , standard for DN 80to150							6	
	600 cm <sup>2</sup> , large size actuator for DN 50 and 65							7	
Function, size	D.A. - Air to close, fail to open								1
	R.A. - Air to open (reverse), fail to close								2
Spring range	20 ... 50 kPa								2
	70 ... 100 kPa								7

## Dimensions of actuators series PA-2000

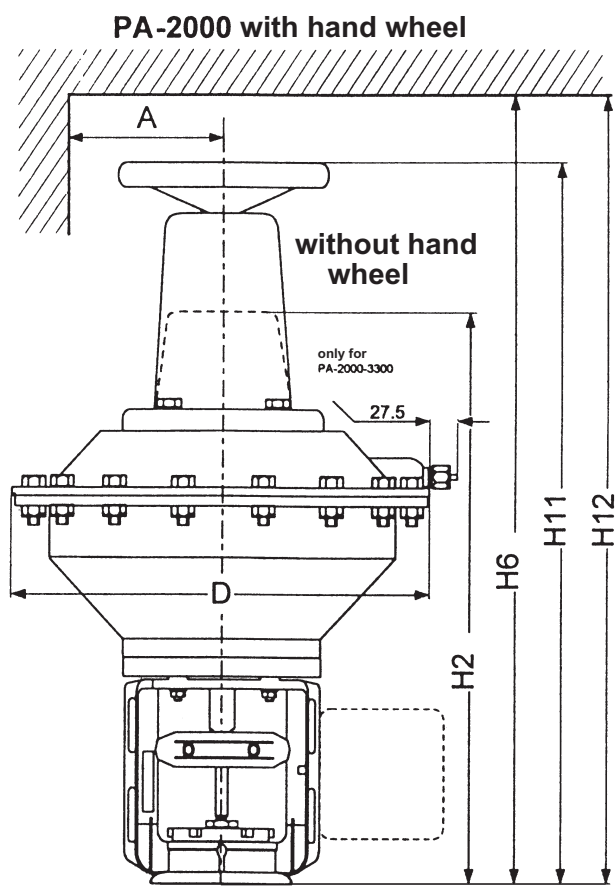

PA-2000-3300

DN	A	D	H2	H6	H11	H12
50 a 65	200	290	378	528	492	642

PA-2000-3600 and PA-2000-3700

DN	A	D	H2	H6	H11	H12
50 - 150	250	384	508	708	666	866

## Maximal permissible operating pressures [MPa]

Material	PN	Temperature [ °C ]										
		120	150	200	250	300	350	400	450	500	525	550
Brass	16	1,60	1,14	---	---	---	---	---	---	---	---	---
42 3135		---	---	---	---	---	---	---	---	---	---	---
Grey cast iron EN-JL 1040 (EN-GJL-250)	16	1,60	1,44	---	---	---	---	---	---	---	---	---
		---	---	---	---	---	---	---	---	---	---	---
Spheroid. c. iron EN-JS 1025 (EN-GJS-400-18-LT)	16	1,50	1,40	1,40	1,30	1,10	---	---	---	---	---	---
	40	4,00	3,88	3,60	3,48	3,20	---	---	---	---	---	---
Cast steel 1.0619 (GP240GH)	16	1,60	1,50	1,40	1,30	1,10	1,00	0,80	---	---	---	---
	40	4,00	4,00	3,90	3,60	3,20	2,70	1,90	---	---	---	---
CrMoV steel		---	---	---	---	---	---	---	---	---	---	---
1.7357 (G17CrMo5-5)	40	4,00	4,00	4,00	4,00	4,00	4,00	3,90	3,10	1,80	---	---
Stainless cast steel 1.4581 (GX5CrNiMoNb19-11-2)	16	1,60	1,50	1,40	1,30	1,30	1,20	1,20	---	---	---	---
	40	4,00	3,80	3,50	3,40	3,30	3,10	3,00	---	---	---	---